

# **INSTRUCTIONS FOR CONTINUED AIRWORTHINESS**

**Aero Twin, Inc. Single Place Folding Seat P/N FS206-100  
and Floor Kit No. AFS-206-200**

for

**Cessna Models 206H and T206H Aircraft**

Document No. FS206-1A-ICA

Maintenance Manual  
Airworthiness Limitations  
Illustrated Parts List

FAA/DAS Approved:

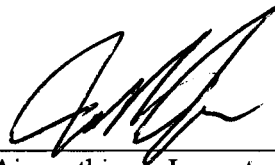

---

DAS Airworthiness Inspector  
Designated Alteration Station DAS-01-AK  
Anchorage, Alaska

Date: March 16, 2001



<h1>Table of Contents</h1>
----------------------------

<b>Section</b>	<b>Page</b>
<b>Log of Revisions.....</b>	<b>2</b>
<b>Table of Contents.....</b>	<b>3</b>
<b>1.0 Maintenance Manual .....</b>	<b>4</b>
<b>1.1 Description.....</b>	<b>4</b>
<b>1.2 Installation/Removal.....</b>	<b>5</b>
<b>1.3 Storage.....</b>	<b>7</b>
<b>1.4 Weight and Balance .....</b>	<b>7</b>
<b>1.5 Maintenance Instructions .....</b>	<b>11</b>
<b>2.0 Airworthiness Limitations.....</b>	<b>15</b>
<b>3.0 Illustrated Parts List .....</b>	<b>17</b>
<b>3.1 Complete Parts List .....</b>	<b>17</b>
<b>3.2 Folding Seat Overview &amp; Back Rest Cover Installation .....</b>	<b>18</b>
<b>3.3 Seat Bottom Hardware &amp; Lower Arm Installation .....</b>	<b>19</b>
<b>3.4 Seat Pan Assembly &amp; Seat Back Installation.....</b>	<b>20</b>
<b>3.5 Lower Arm Detail .....</b>	<b>21</b>
<b>3.6 Seat Pan Installation.....</b>	<b>22</b>
<b>3.7 Anchor fitting .....</b>	<b>23</b>

**1.0****Maintenance Manual****Aero Twin, Inc. Single Place Folding Seat, P/N FS206-100 and Floor Structure  
Kit No. AFS-206-200****1.1 Description**

The Aero Twin single place folding seat for the Cessna 206H and Cessna T206H is designed for quick and simple installation and removal, and compact stowage when not in use. Brownline style utility track is installed on the aft cabin floor. This new track is capable of receiving the above-mentioned Aero Twin folding seats or appropriate cargo restraint fittings.

The basic structure of the seat is a welded 4130 steel tube frame. The seat back and legs fold for storage. Two diagonal arms, each hinged at one end and equipped with a quick-release fitting at the other, provide primary structural support for the installed seat. The seat pan is rubber-impregnated high-strength fabric attached to the seat frame with aluminum inserts using sheet-metal screws. The seat back cover is of the same material; it slides over the seat back frame and is secured with nylon straps. Occupant restraint is provided by lap belts attached to the seat frames and diagonal shoulder harnesses, attached to the airframe. The seat is equipped with four identical anti-rattle type track fittings that engage the seat tracks. A one-piece padded back rest cover is supplied with each seat; this slides over the seat frame and is secured with hook-and-loop strips. The seat is identified by a data plate permanently attached to the back rest lower cross-member. The data plate lists the part number, serial number, and date of manufacture of the seat.

The passenger compartment utility track installation consists of under floor structural additions for supporting the medium duty Brownline Utility track. Structural screws are used to attach the track to the under-floor structure.

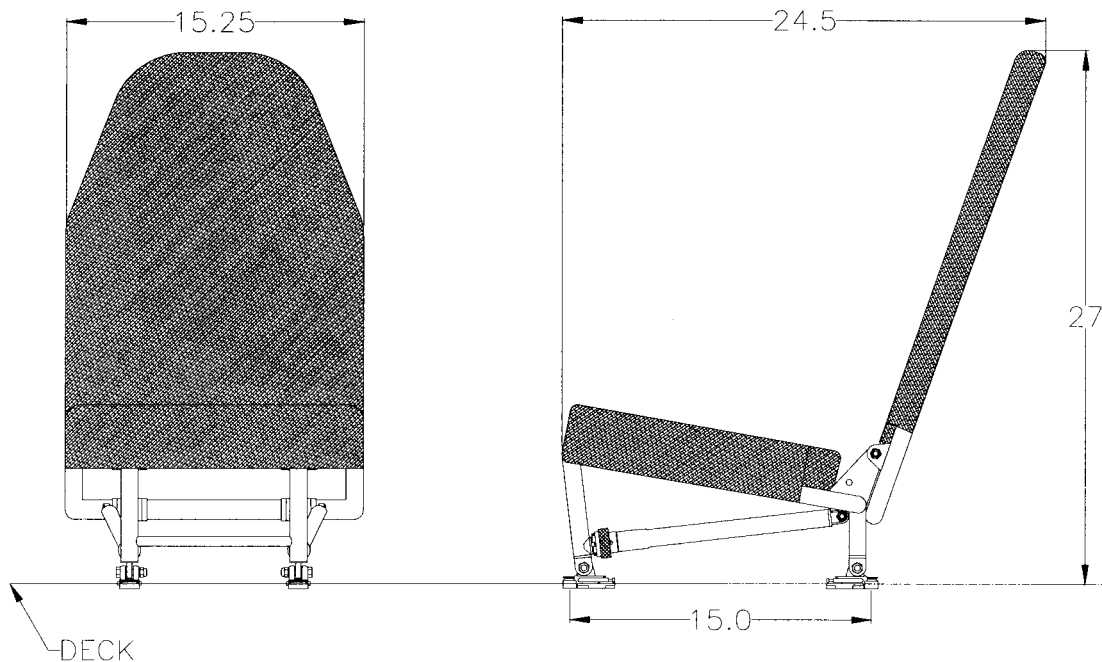

**Figure 1.1.1 Basic Seat Dimensions**

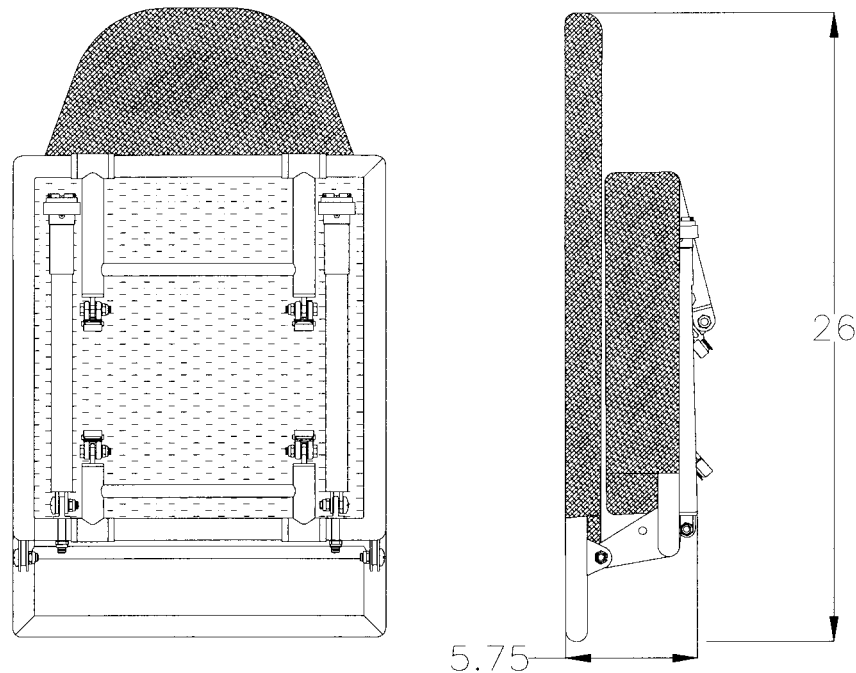

**Figure 1.1.2 Folded Seat Dimensions**

## **1.2 Installation / Removal**

---

**NOTE: This seat is certified for forward-facing installation only.**

This section describes general Aero Twin passenger seat installation procedures.

### **1.2.1 Setup and Installation:**

1. Unfold forward leg and lower diagonal arms. On each quick-release fitting (item -11), push in the retaining pin and retract the locking ring (see detail in Figure 1.2.1). Position the diagonal arms to align fittings with studs on forward leg. Push forward leg back to engage studs in fittings, then extend locking rings to close jaws.

**Be sure jaws close completely and retaining pins pop out to the extended (locked) position - Failure to properly engage studs and lock fittings could result in seat collapse.**

2. Unfold rear leg and position the seat over the seat tracks at the desired fuselage station. Drop the forward feet into the tracks (locking lugs must be in the retracted position), slide forward or aft 1/2 inch, and push the locking lugs down to lock the forward feet into the track.
3. Extend the rear legs afterward to the built-in rotation stop, then move legs forward until aft feet can drop into the tracks. Slide feet aft 1/2 inch and push locking lugs down to lock feet in track. Locking lugs of rear feet should be 15 inches (15 track positions) aft of forward feet locking lugs.

4. The feet are equipped with anti-rattle devices. Use is optional. To use the anti-rattle feature, tighten the screw in the anti-rattle device until the stirrup is drawn snug against the seat track.
5. Fold seat back to full upright position.
6. Update aircraft empty weight and balance to account for seat installation (see Section 1.4).

### 1.2.2 Removal / Breakdown:

1. Release anti-rattle feature on each of four feet (if feature is utilized).
2. Lift the rear feet locking lugs (a tool designed for this purpose is supplied with the seat; additional tools are available from Aero Twin, Inc.). Slide the feet forward 1/2 inch and lift the feet from the track.
3. Repeat step 1 for the forward feet. Remove seat from tracks.
4. Push in the retaining pins and retract the locking rings of the lower diagonal arm quick-release fittings. Disengage the forward leg studs from the fittings.
5. Fold the rear legs up, then the forward legs. Fold the arms into position alongside the forward legs.
6. Fold the seat back down.

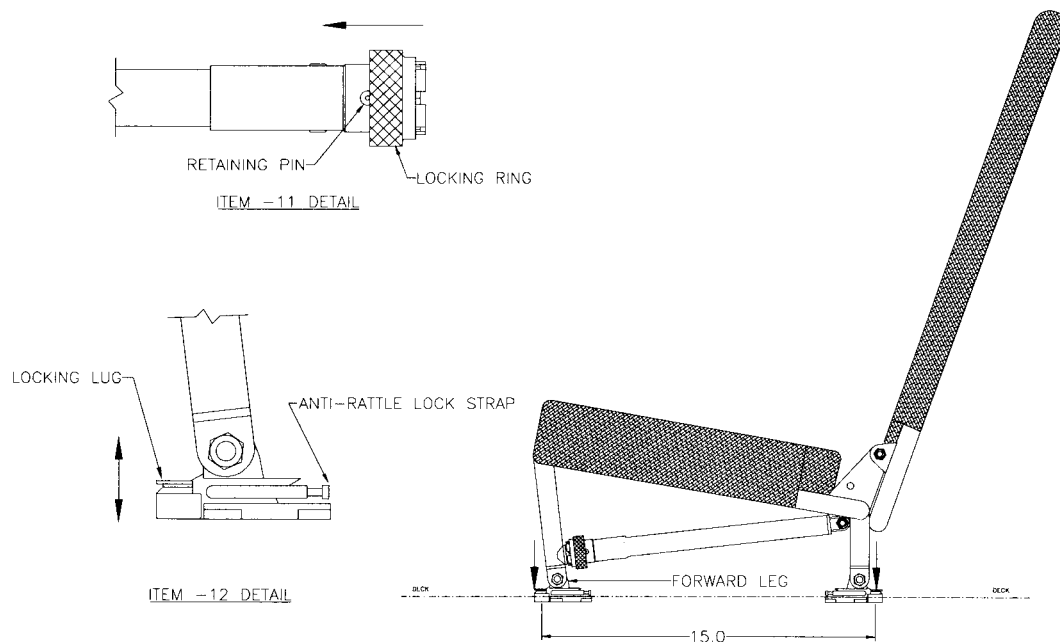

**Figure 1.2.1 Seat Installation**

### 1.3 Storage

---

A protective storage bag is provided with each seat. For long-term storage it is recommended that the seat be placed in its protective bag. During storage the seats should be kept in a dry location away from any direct heat source.

The seats can be stacked up to six-deep in storage. Do not stack more than 100 lb. on top of a folded seat. Prior to installing a seat which has been in storage for an extended period, inspect and lubricate the seat in accordance with a 1000 hr/Annual inspection.

### 1.4 Weight and Balance

---

When any seats are installed or removed, the aircraft empty weight and balance must be updated to reflect the configuration change. This section includes information required for weight and balance calculations pertaining to the installation of Aero Twin seats. The under-floor structure and brown-line additions should be included in the aircraft basic empty weight at the time of initial installation.

#### 1.4.1 Calculation of Effect on Aircraft Empty Weight and Balance:

When installing Aero Twin single place folding seats in any configuration, the effect on aircraft empty weight and moment must be determined for that configuration.

Individual seat weights are as shown below:

**Aero Twin P/N FS206-100 Folding Seat: Weight = 18 lb.**

The empty seat center of gravity location is 11.7 inches aft of the forward feet locking lugs. See Figure 1.4.1.

#### 1.4.2 Seat Location

---

**When a seat is installed for aft passenger seating, there is only one approved position.** This position places the locking plunger of the front foot of the seat at FS 96.3. Note there are three screws attaching the track to the fuselage at FS 96.3. See fig. 1.4.1(b) for detail. The aft seat locking plunger, for the front seat leg, is installed over the center of these screws. This places the aft seat in the correct position. The Brownline track comes pre-marked with an "A" denoting the location of the forward seat locking plunger. By placing the forward foot locking plunger at this location, the aft seat will be in the correct position.

### **▲ WARNING**

**Aero Twin, Inc. Single Place Folding Seats are only approved for installation with the forward feet locking plungers at FS 96.3. No other aft seat positions are approved for flight operations.**

The center of gravity for a typical occupant is 8.8 inches aft of the forward feet locking lugs. To position a seat so that its occupant's C.G. is at a given station, install the seat in the tracks with the forward feet locking lugs 8.8 inches forward of that station.

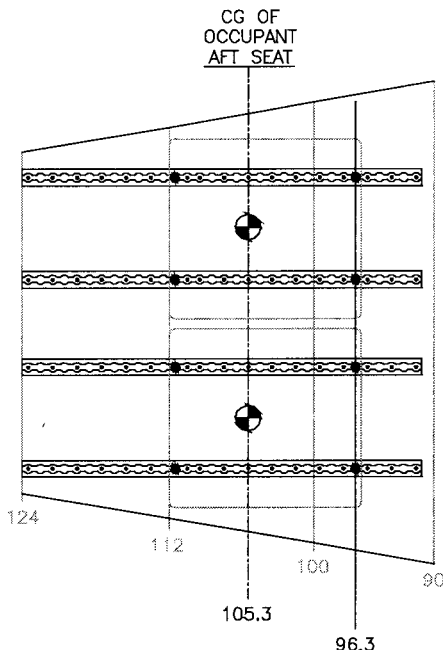

**Figure 1.4.1(a) Seat Position and Rail Layout**

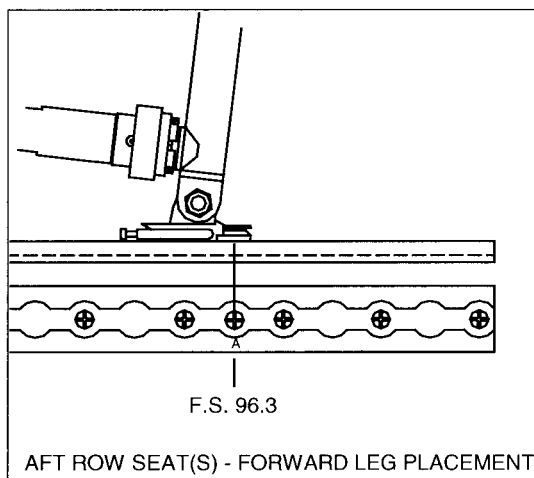

**Figure 1.4.1(b) Seat Position**

**1.4.3 Calculation of Effect on Aircraft Empty Weight and Balance:**

When the aircraft is equipped with Aero Twin, Inc. Single Place Folding Seats in accordance with the Supplemental Type Certificate (STC), a new empty weight and balance must be computed and incorporated in the aircraft records. The weight and balance data for any existing cabin seating must be modified or replaced with data for the new seats and seating arrangement.

Methods for calculating empty aircraft weight and balance are discussed in the basic Pilot's Operating Handbook and FAA Approved Flight Manual. Data specific to the Aero Twin, Inc. Single Place Folding Seat (empty weights and center of gravity locations) are provided in the Instructions for Continued Airworthiness, Airplane Flight Manual Supplement, and Installation Instructions supplied with the seat(s).

**Weight of one FS206-100 seat assembly:                    18 pounds**

*(includes restraint system, pads and upholstery)*

**Moments of Installed Seat(s):**

Weight, arm, and moment for a single installed seat, unoccupied:

Row	Position	Wt.	Arm	Moment/1000
Aft row seat	A	18	108	1.9

Weights and moments of installed seats are added to the weight and moment of the empty airplane (without passenger seats); dividing total moment by total weight yields the C.G. of the empty airplane *with* passenger seats.

NOTE: Seats may be used in any arrangement of one or two seats, as long as the individual seats are positioned in accordance with this paragraph.

Seats that are stowed for cargo or combined operations are treated as cargo in accordance with the basic POH/AFM.

**PASSENGER LOADING, WEIGHT AND BALANCE:**

Passenger center of gravity for each seat position:

Row	Position	Wt.	Arm	Moment/1000
Aft row seat	A	**	105.3	(17.9)

*\*\* Numbers in parenthesis are for a typical 170 lb passenger; use actual passenger weights.*

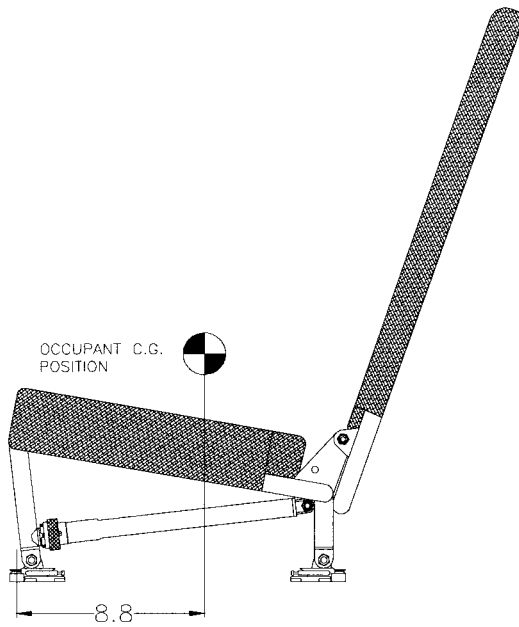

Figure 1.4.2

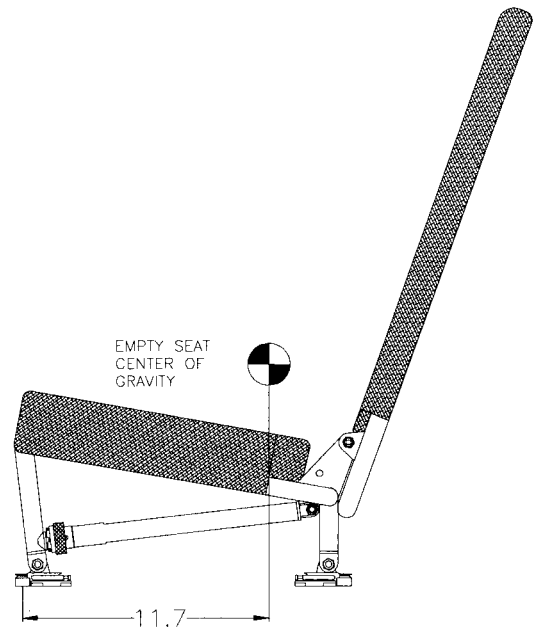

Figure 1.4.3

#### 1.4.4 Weight and Balance Considerations for Operating the Aircraft with the Original Cessna Seats

If it is desired to operate the aircraft with the original Cessna seats installed it is necessary to remove part of the Aero Twin seat track installation. The changes made must be reflected in the aircraft Basic Empty Weight. Do not remove permanently installed parts. The seat rails and the fasteners for the seat rails should be removed for access to the original Cessna seat attach points. The weights that should be subtracted from the aircraft Basic Empty Weight are as follows:

Rear Seat Track: Weight = 2.5 lbs., CG Location = FS 106.5  
Weights include the screws used for fastening the seat rails.

## 1.5 Maintenance Instructions

---

### 1.5.1 General:

The Aero Twin Single Place Folding Seat and Utility Track installation is designed to be highly durable and fairly maintenance free. However, a maintenance program has been established, in accordance with Appendix G of FAR 23, to assure the continued airworthiness of the seats and track installation. Adherence to the established plan is mandatory and records of performance of required inspections and maintenance must be maintained. See Section 2.0, Airworthiness Limitations, for required maintenance items and intervals.

### 1.5.2 Cleaning:

#### 1.5.2.1 Upholstery:

- For general dust and light dry soiling, vacuum upholstery thoroughly, and or brush with a clean stiff bristle brush. Avoid beating fabric as this can hasten wear and does not effectively clean the upholstery. Use of commercially available upholstery shampoo will remove most soil encountered in normal service. Follow product directions.
- For oil or grease stains, solvent-type cleaning agents can be effective. Test a small inconspicuous area of the fabric first. Use solvent-type agents sparingly, without saturating fabric. Apply with a clean soft cloth and work from the edge of the stain towards the center to avoid spreading. Observe appropriate safety precautions when using any solvent agent.
- For heavy, saturating stains (coffee, vomit, etc.) the upholstery cover should be removed and commercially dry-cleaned.

#### 1.5.2.2 Seat Track:

The track should be kept clean, as dirt and contaminants can wear on the track and cause difficulty in installing and removing hardware. Cleaning may be done in a variety of ways as long as chemicals or tools used do not corrode or wear down the track.

#### 1.5.2.3 Herculite fabric (seat pan and seat back cover):

Clean the Herculite fabric components using mild soap and water solution or a commercial vinyl cleaner. For heavy grease or oil stains, a diluted solution of Simple Green or equivalent cleaning solution can be used. Avoid excessive wetting of the fabric when installed on the seat, as moisture can collect between the fabric and tube structure and promote corrosion.

#### 1.5.2.4 Metal Parts:

Moisten a clean soft cloth with a solvent-type cleaner or undiluted Simple Green or equivalent; thoroughly wipe metal parts completely clean. Wipe dry with a clean dry cloth. After heavy cleaning over or near lubricated joints, relubricate as appropriate.

### 1.5.3 Lubrication and Corrosion Prevention:

The hinged leg connections to the seat frame are areas that must be kept well lubricated and protected from moisture. *Corrosion X*™ is a product that is well suited to this dual purpose. This product is available from Aero Twin, Inc., or your local aviation supplier. Other commercial

products are available that will perform well. WD-40 is not recommended, as its moisture displacement properties are inadequate.

Procedures for corrosion prevention used during already mandated fuselage inspections should be directly applied to the additional ribs and members in the under-floor installation.

The required maintenance procedures for the seat include lubrication and internal treatment of the steel tubes at specific intervals. The seat should also be lubricated if it is subjected to heavy moisture for any reason, or after thorough cleaning of the metal frame.

- To lubricate the rotating and sliding joints, spray lubricant into the joint while rotating or sliding the fitting (avoid over spray on the upholstery cover by first pulling the cover back from the joint). Wipe off all excess lubricant with a clean dry cloth.
- To internally treat the steel tubes, the upholstery cover and Herculite fabric seat pan and seat back cover should be removed. Using a small nozzle, spray *Corrosion X™* (or equivalent) into all available holes. Allow the frame to sit for several minutes to allow excess to drain as it may, then wipe off all external surfaces with a clean, dry cloth. Reassemble seat.
- If the painted surface of the steel tube structure is marred in service or during handling, the affected area should be repainted to prevent corrosion. See instructions in section 1.5.5.3.

#### **1.5.4 Disassembly / Assembly:**

##### 1.5.4.1 Disassembly:

- To remove the padded upholstery backrest cover, the shoulder harness must be removed. Pull the flap free from the hook-and-loop strips on the lower part of the back rest, then slide the cover up and off the back.
- To remove the seat cushion and upholstery: disconnect the 3 flaps from the hook and loop strips on the sides and front of the seat pan. Pull the cushion and upholstery forward off the pan.
- To remove the Herculite seat back cover, loosen and release the strap buckles on the aft side of the seat, then slide the cover off of the seat back frame.
- To remove the Herculite seat pan, remove the sheet metal screws from the underside of the seat frame.
- Disassembly of the seat frame is straightforward, as all connections utilize standard aircraft hardware.
- The under-floor portions of the utility track installation are considered permanent.

##### 1.5.4.2 Assembly:

Refer to the Illustrated Parts List when reassembling the seat frame.

Replace self-locking type nuts with new hardware when reassembling seat.

Any time the Herculite seat pan is removed, use new screws for reinstallation.

Use standard torques except as follows:

- The nuts on the seat back hinge bolts, which retain the lap belts, should be snug but not over-tight to allow rotation of the seat back and the lap belt fittings.
- The nuts on the clevis bolts at the upper ends of the two arm assemblies, and the nuts that retain the two eyebolts to which the arms attach, should be snug but not over-tight to allow rotation of the arms for folding.

- The nuts and bolts which attach the feet (seat track fittings) to the eyebolts at four locations should not be tightened so much as to cause distortion of the cast lugs on the fitting.

#### 1.5.4.3 Adjustments:

- Arm Assemblies: These members are not adjustable.

### 1.5.5 Seat Repair:

#### 1.5.5.1 Hardware Replacement:

Hardware and fittings used throughout the seat are aircraft standard. Hardware should be replaced if corroded, damaged, or excessively worn. Replace self-locking type nuts with new hardware when reassembling seat. Do not substitute hardware - refer to the Illustrated Parts List for correct part numbers. If you encounter difficulty procuring replacement hardware or fittings, contact Aero Twin, Inc. at (907) 274-6166. Refer to previous section for assembly information.

#### 1.5.5.2 Steel Tube Frame:

**Before any repairs may be made to the steel tube frame, written approval must be obtained from the manufacturer, Aero Twin Inc. Contact Aero Twin Engineering Department at (907) 274-6166 or write: Aero Twin Inc., Engineering Dept., 2404 Merrill Field Dr., Anchorage AK, 99501.**

**NOTE: Arm Assemblies (P/N FS1-500), are not eligible for repair. If these parts are found to be bent or cracked, they must be discarded and replaced.**

#### 1.5.5.3 Painted Surfaces:

Painted steel surfaces should be maintained and refinished as required to prevent corrosion. When refinishing is required, lightly sand the affected area using fine sandpaper or an abrasive pad (such as 3M *Scotch-Brite*<sup>TM</sup>). Polish out minor surface nicks or scratches where present. Clean the area thoroughly with a clean cloth wetted with non-petroleum-based solvent to remove any residual oils and dust. Apply a zinc-chromate or equivalent primer coat, then a matching color coat of quality enamel or epoxy-type paint. Follow manufacturer's instructions in preparing and applying primer and color coats.

#### 1.5.5.4 Fabric:

- Herculite Components: These components are subject to mandatory replacement at ten-year intervals, but should be replaced when found to be excessively worn, frayed, or torn. Open seams can be re-stitched using nylon thread.
- Upholstery: Re-stitch open seams using nylon thread. Small tears can be drawn closed and sewn. Extensive damage usually justifies replacement of the upholstery cover.
- Foam: The seat is not approved for operation without the foam supplied with the seat, or equivalent. Padding should only be replaced with medium density highly damped, semi-reticulated urethane foam. Confor Foam CF-45 (bottom layer), CF-40 (middle layer), and DAX-55 scrim (top layer) are acceptable replacements.

**1.5.5.5 Restraint Belts:**

Worn, frayed, cut, or otherwise damaged belt assemblies should be replaced or remanufactured by a qualified repair station. Any belt assembly that is found to be missing it's manufacturer's data patch must be considered unairworthy and must be replaced.

**1.5.6 Floor Structure Repairs:**

Repairs to the utility track are not authorized, contact Aero Twin Inc. for replacement parts. For repairs to the under-floor structure, use approved standard practices.

**2.0****Airworthiness Limitations****Aero Twin, Inc. Single Place Folding Seat P/N FS206-100  
Floor Kit No. AFS-206-200**

**The Airworthiness Limitations section is FAA/DAS approved and specifies maintenance required under paragraphs 43.16 and 91.403(c) of the Federal Aviation Regulations unless an alternative program has been FAA approved.**

This section describes required inspection, maintenance, and replacement items. When repairs are deemed necessary, follow accepted standard practices and/or specific maintenance instructions in Section 1.5 of this manual. This section constitutes Component Airworthiness Limitations which apply to the seat and utility track installation only.

**2.1 Scheduled Inspections and Maintenance:**

Note: First inspection should be accomplished at next aircraft inspection so that subsequent inspections coincide.

**2.1.1 First 100-hour and subsequent 1000 hour or Annual Inspection:**

Visually inspect the tracks for secureness. The track will be inspected for damage that would compromise its ability to fasten and secure. An example of unacceptable damage would be bent, broken, cracked or extremely worn securing tabs. The seat track should be free from debris.

**2.1.2 1000 hour or Annual Inspection:**

Remove padded upholstery cover.

Inspect steel tube frame:

Tubes for bends, dents, corrosion, or other defects.

Welded areas for cracks or other defects.

Finish for scratches, abrasion, etc.

Inspect hardware and fittings:

Hardware for security and condition.

Quick-release fittings for proper operation and condition.

Feet (track fittings) for proper operation, security, and condition.

Inspect Herculite fabric (seat pan and seat back cover):

Fabric for wear, fraying, tearing, or other defects

Attachment screws (seat pan) for security

Straps and buckles (seat back) for condition and tautness

Inspect restraint system (lap belts and shoulder harness assemblies):

Webbing for cuts, fraying, or other defects.

End fittings for security and condition.

Buckles for proper operation.

Data patches (must be present and legible).

Inspect overall seat assembly and upholstery for cleanliness and general airworthiness.

Lubricate all rotating and sliding parts fittings (Corrosion X™ or equivalent).

Reinstall padded upholstery cover.

**2.1.3 Subsequent inspections:**

1. The additional floor structure will be incorporated into the Internal Fuselage Structure Inspection (Item Code Number 531003). The seat track itself should be inspected according to item 2.1.1.

**2.1.4 Five-Year Inspection:**

Remove padded upholstery cover.

Remove Herculite seat pan and seat back cover.

Inspect steel tube frame:

All welded joints using a 10X glass for cracks.

(Strip paint from area around any apparent crack and re-inspect).

Treat all tubing internally with corrosion preventative (*Corrosion X™* or equivalent).

Complete all items for a **1000 Hour / Annual Inspection**.

Reinstall seat pan using new screws; reinstall seat back cover and upholstery cover.

**2.1.5 Ten-Year Inspection:**

Remove padded upholstery cover.

Remove Herculite seat pan and seat back cover and discard.

Disassemble seat frame.

Strip paint from all welded joints and inspect using a 10X glass.

Complete all items for a **5-Year Inspection**.

Repaint seat frame components.

Reassemble seat frame using new hardware.

Install NEW Herculite seat pan and seat back cover

Reinstall padded upholstery cover.

FAA/DAS Approved: \_\_\_\_\_

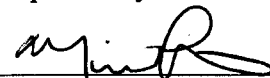
  
DAS-01-AK

-----End of Section 2.0 Airworthiness Limitations-----



### 3.2 FOLDING SEAT OVERVIEW & BACK REST COVER INSTALLATION

-8	ATFS-133	BUCKLE
-5	FS1-700	BACK REST ASSEMBLY
-3	FS1-500	ARM ASSEMBLY
-2	FS1-400 L/R	SEAT BACK FRAME
-1	FS1-100	SEAT PAN FRAME
ITEM	PART NO.	DESCRIPTION

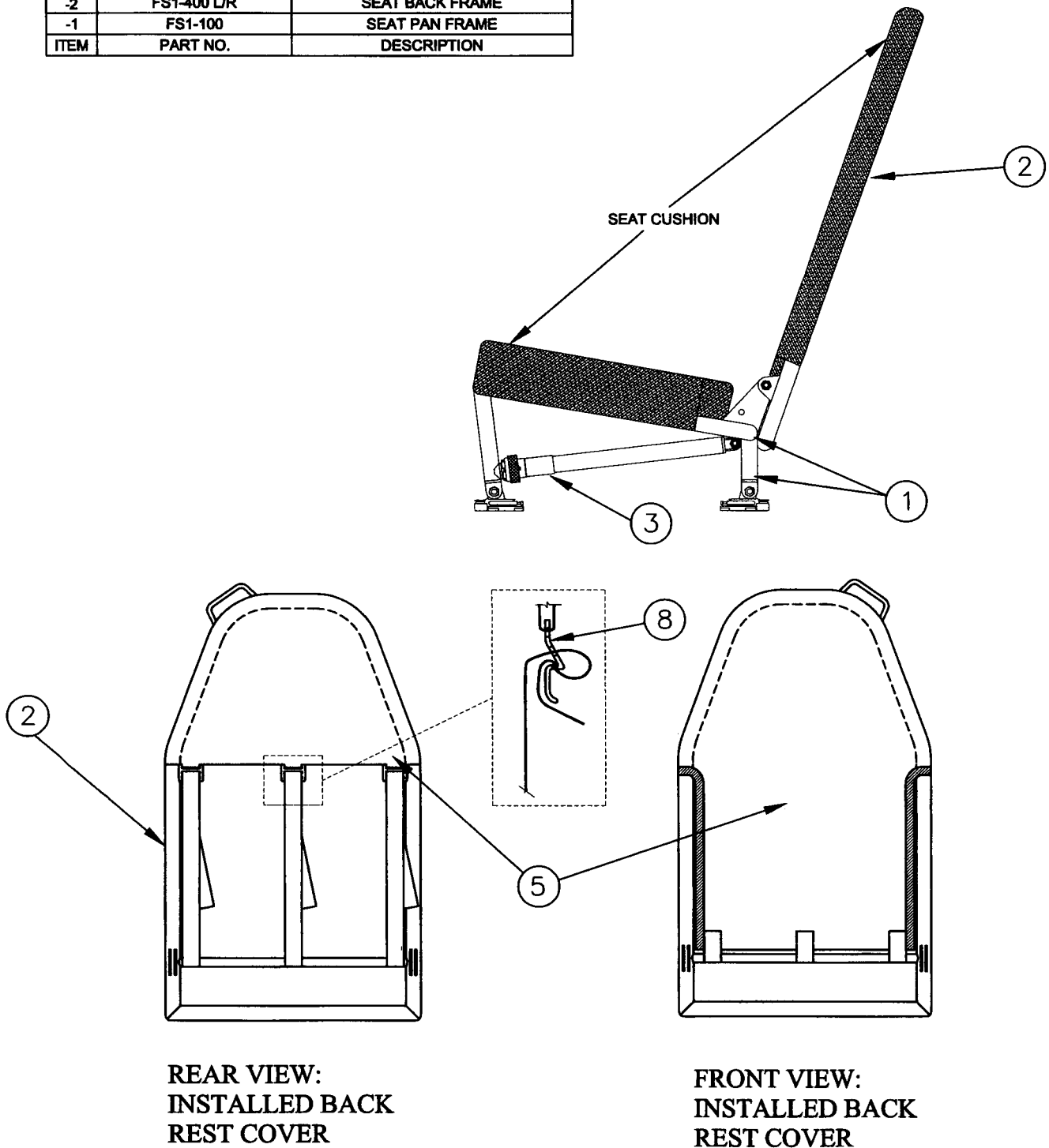
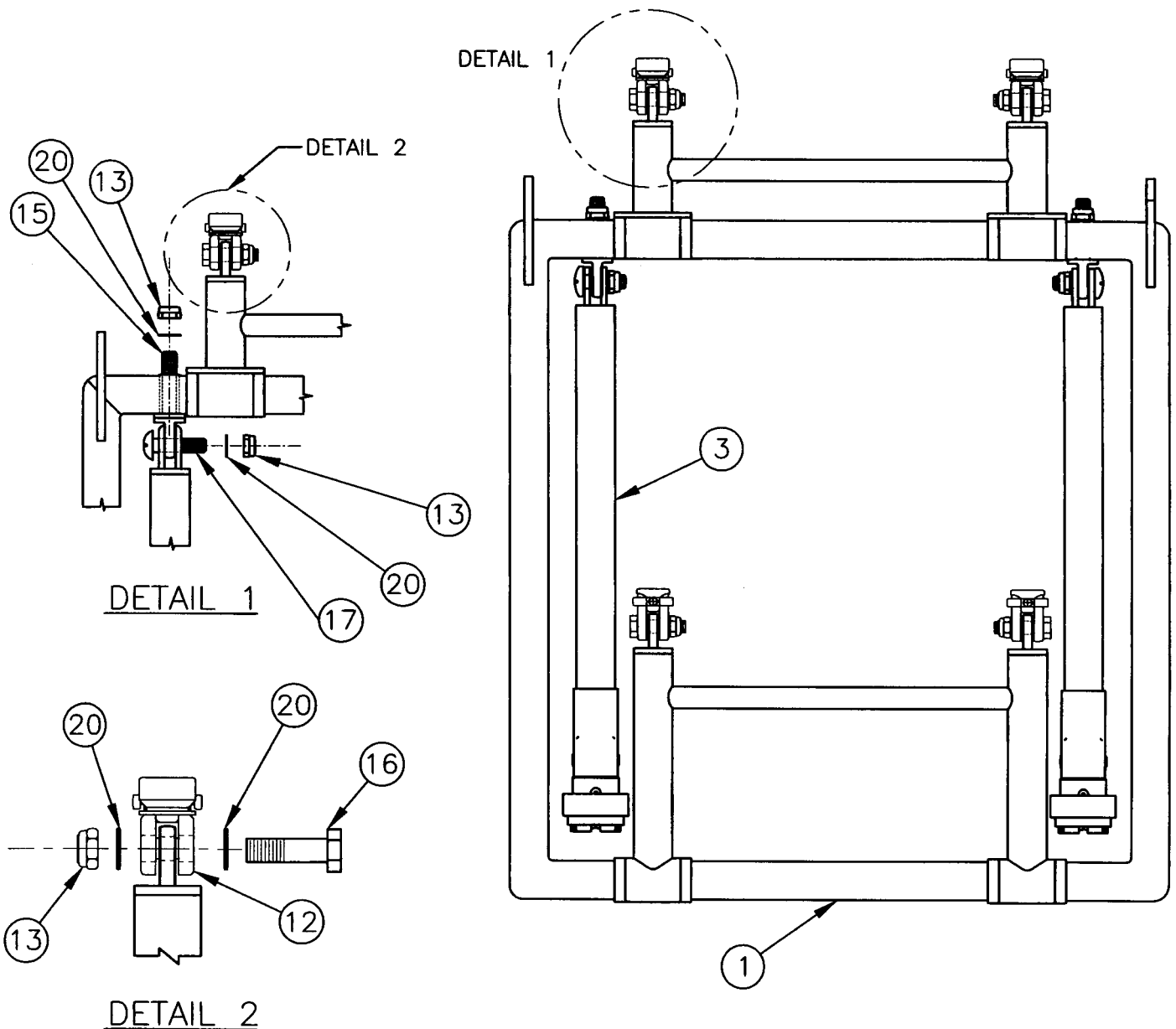

FIGURE 3.2

### 3.3 SEAT BOTTOM HARDWARE & LOWER ARM INSTALLATION

-17	AN25-14A	CLEVIS BOLT
-16	AN5-10A	BOLT
-15	ATFS-62H	EYE BOLT
-20	NAS1149F 0532P/0563P	WASHER
-13	MS21083N5	LOCK NUT
-12	40566-14	RETAINER
-3	FS1-500	ARM ASSEMBLY
-1	FS1-100	SEAT PAN FRAME
ITEM	PART NO.	DESCRIPTION



### 3.4 SEAT BELT AND BACK INSTALLATION

-18	AN24-12A	CLEVIS BOLT
-17	AN25-14A	CLEVIS BOLT
-13	MS21083N5	LOCK NUT
-7	NAS75-4-007	STEEL BUSHING
-6	MS21083N4	NUT
-2	FS1-400 L/R	SEAT BACK FRAME
-1	FS1-100	SEAT PAN FRAME
ITEM	PART NO.	DESCRIPTION

-22	5-02-606701	SEAT BELT ASSEMBLY
-21	NAS1149F 0432P	WASHER
-20	NAS1149F 0563P/532P	WASHER
-19	ATFS-115A	STEEL BUSHING
ITEM	PART NO.	DESCRIPTION

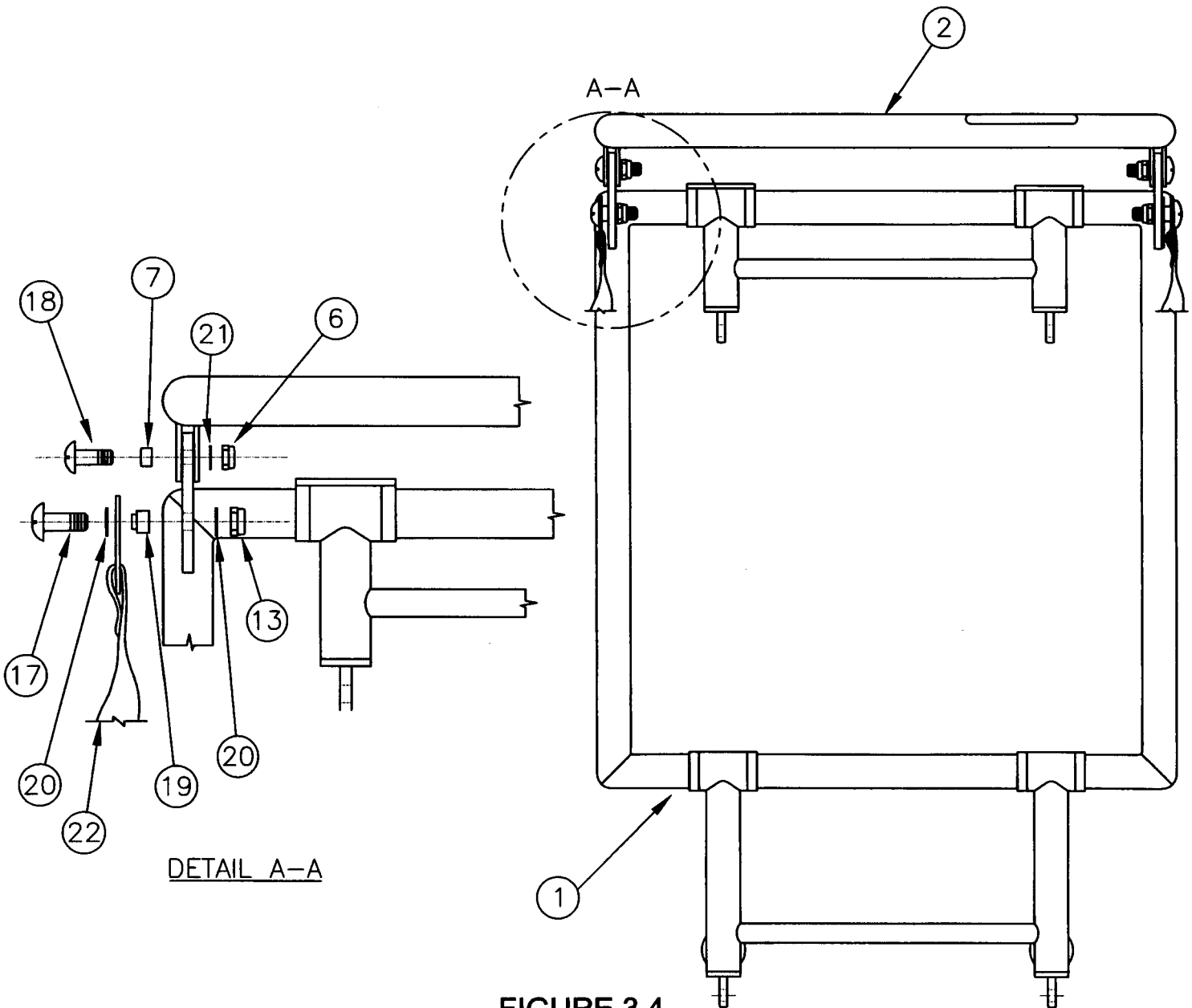

FIGURE 3.4

### 3.5 LOWER ARM DETAIL

-11	MS22034-1	RETAINER FITTING
-23	NAS561P6-16	ROLL PIN
-10	NAS561P8-18	ROLL PIN
-3	FS1-500	ARM ASSEMBLY
ITEM	PART NO.	DESCRIPTION

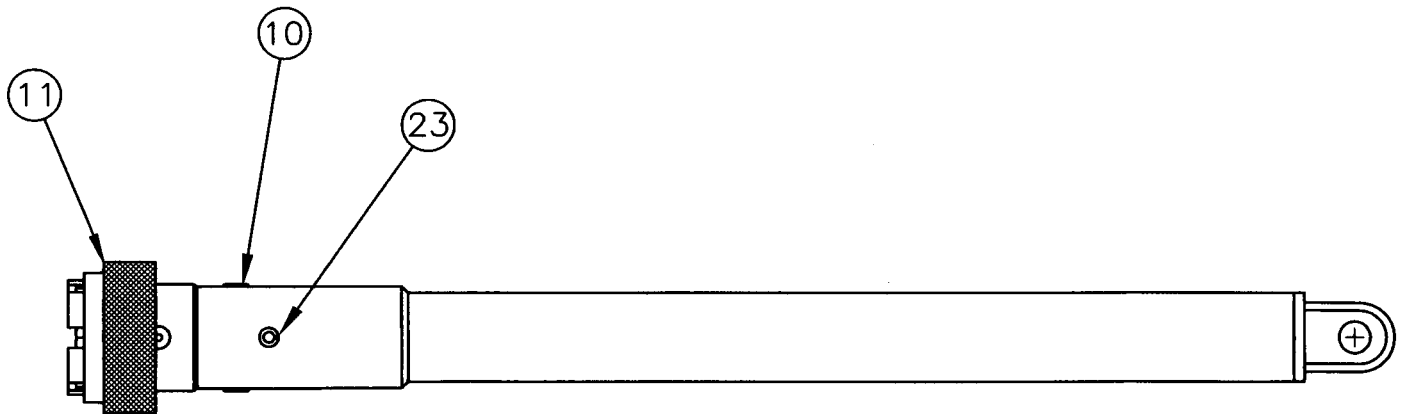
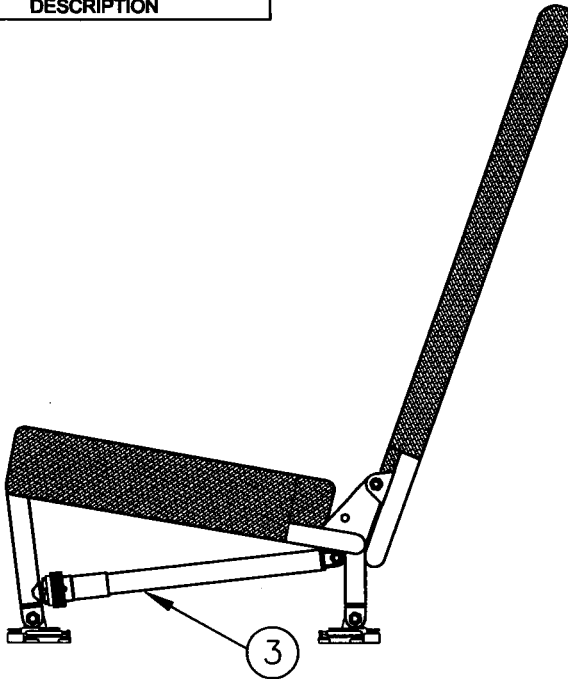

FIGURE 3.5

### 3.6 SEAT PAN INSTALLATION

ITEM	PART NO.	DESCRIPTION
-9	MS51863-23C OR S1021A6-8	SEAT PAN SCREW
-4	FS1-600	SEAT PAN ASSEMBLY
-1	FS1-100	SEAT PAN FRAME
-24	FS1-605	SEAT CUSHION FOAM

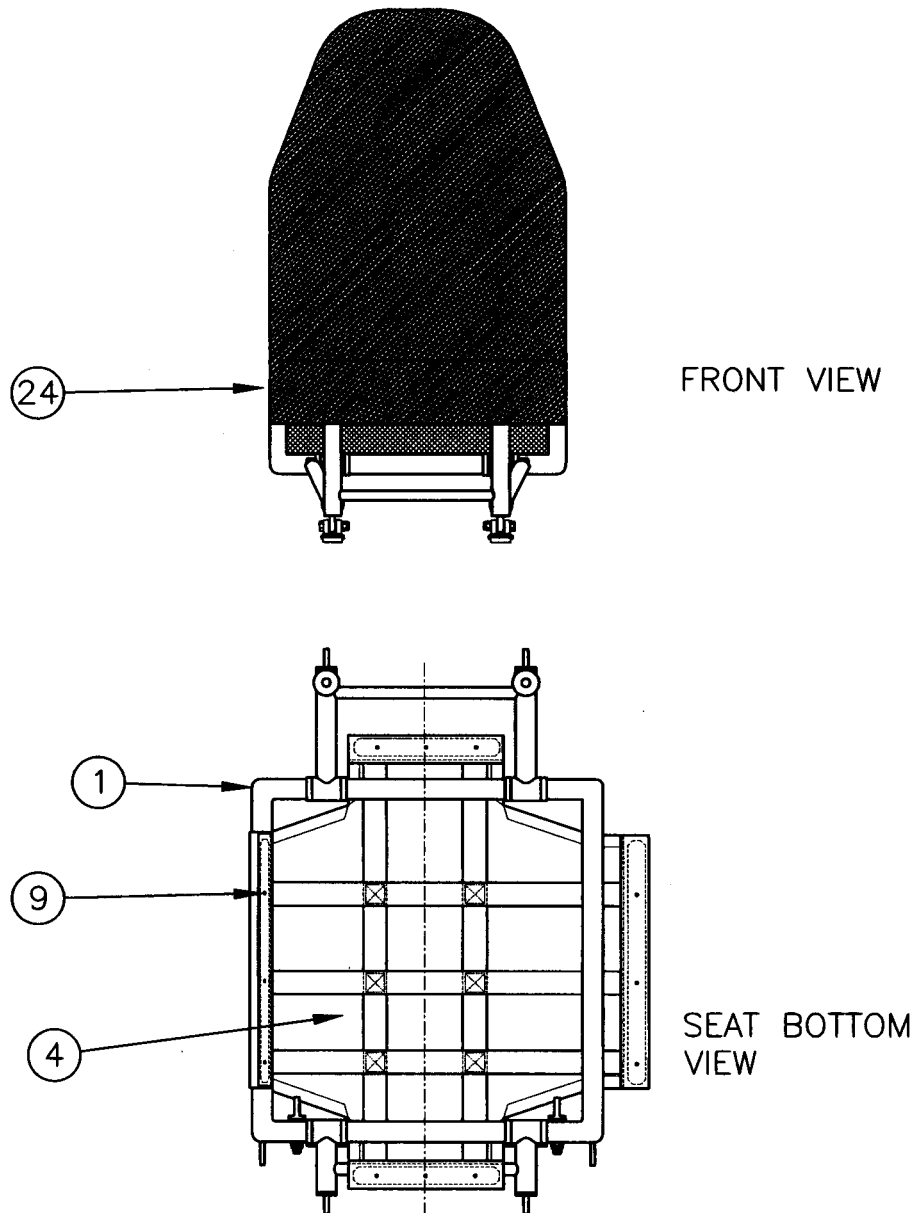

FIGURE 3.6

### 3.7 SHOULDER HARNESS ANCHOR

---

-25	40149-14	RING STUD
ITEM	PART NO.	DESCRIPTION

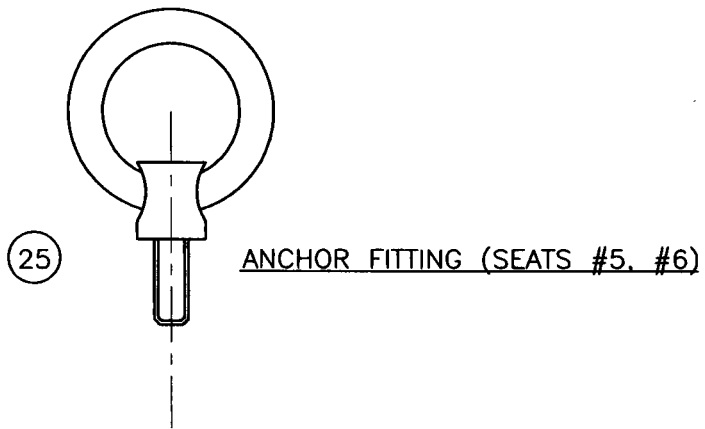

FIGURE 3.7