



AERO TWIN, INC.

**Aero Twin, Inc. Anti-Fog Window Liner Kits
No. ATSW8 For Cessna Model 208
No. ATSW8-B For Cessna Model 208B**

INSTRUCTIONS FOR CONTINUED AIRWORTHINESS

Aero Twin, Inc. Document No. ATSW8-ICAW

Maintenance Manual

Illustrated Parts List

FAA/DAS Approved:

DAS Airworthiness Inspector
Designated Alteration Station DAS-01-AK
Anchorage, Alaska

Date: June 29, 2000

LOG OF REVISIONS			
REVISIONS		PAGES REVISED AND DESCRIPTION OF REVISIONS	APPROVAL SIGNATURE
NO.	DATE		
--	06/29/00	Original Issue	

<h2>Table of Contents</h2>

Section	Page
Log of Revisions	2
Table of Contents	3
1.0 Maintenance Manual	4
1.1 Description.....	4
1.2 Installation/Removal	4
1.3 Inspection.....	5
1.4 Repair.....	5
1.5 Cleaning	5
2.0 Illustrated Parts List.....	6

1.0 Maintenance Manual

1.1 Description

The Aero Twin Anti-Fog Window Liner Kit is intended to prevent condensation in the passenger cabin windows by providing an insulating space between the outside cabin windows and the normally warmer air inside the cabin. The window liners are constructed from 1/16" thick clear polycarbonate sheet (Lexan→) with a foam seal strip located around the outer perimeter. The liners are installed against the aircraft windows with the foam seal acting as a spacer. The existing interior trim is used to secure the liner.

1.2 Installation / Removal

NOTE: These supplementary windows are not intended for installation on door windows or cockpit windows.

This section describes general installation procedures.

1.2.1 Setup and Installation:

See Aero Twin, Inc. Document No. ATSW8-IM (Installation Instructions) for full details on installation. In short, the molded interior window trim panels are removed, the liners are placed against the corresponding windows with the foam strip acting as a spacer, and then the interior panels are replaced. The interior panels hold the liners in position.

1.2.2 Removal / Breakdown:

Window liner removal is accomplished by removing the molded interior window trim panels, removing the liners, then reinstalling the interior panels. For long-term storage it is recommended that the liners be covered to protect against direct sunlight, moisture and dust.

1.2.3 Weight and Balance

When supplementary windows are installed or removed, the aircraft empty weight and balance must be updated to reflect the configuration change. Weights and arms for complete kits are shown in Table 1.1.

Weight and Balance Data

A/C Model	Kit No.	Weight (lb.)	Arm (in)	Moment/1000
Model 208:	ATSW8	5.6	212.0	1.19
Model 208B:	ATSW8-B	8.04	232.1	1.87

Table 1.1

1.3 Inspection:

The liners should be visually inspected annually or any time they are removed during airframe scheduled maintenance. Check for cracks and general condition of sheet material. Confirm that the foam seal strip is in good condition and is securely attached to the window. When inspecting installed liners, confirm that liners are centered over the aircraft window. If the foam seal strip is readily visible from inside or outside the aircraft, the liner should be repositioned.

1.4 Repair:

Small cracks found in the liners are to be serviced by stop-drilling as described in AC 43.13-1B chapter 9. It is recommended that the drilled hole be sealed with a drop of clear silicon to retain the insulating characteristics of the liner.

Cracks which extend 2 inches or more from an edge, or which result in the separation of a piece of a liner, are cause for replacement of the entire liner assembly.

Scratches can be polished out using commercially available polishing compounds compatible with Lexan.

Damaged foam seal strip can be replaced, in full or in part, using Cessna P/N P860037 seal strip.

Do not substitute materials when replacing damaged window liners. Refer to the Illustrated Parts List for correct part numbers and contact Aero Twin, Inc. at (907) 274-6166 for replacement parts.

1.5 Cleaning:

Window liners can be cleaned using accepted methods for cleaning aircraft glazing:

- Rinse using lukewarm water; wash gently with mild soap or detergent and lukewarm water, using a soft cloth or sponge. DO NOT SCRUB or use brushes or squeegees.
- Rinse again. Dry with a soft cloth or moist cellulose sponge to prevent water spotting.
- Compatible Cleaning Agents Aqueous Solutions of Soaps and Detergents:
 - Examples: (Fantastik, Formula 409, Hexcel F.O.554, Joy, Lysol, Mr. Clean, Neleco-Placer, PineSol, Top Job or Windex.)™

Note: NEVER USE GASOLINE on this product.

2.0 Illustrated Parts List

Three liner sizes are available, as shown in Figure 2.1. See tables below for applicability.

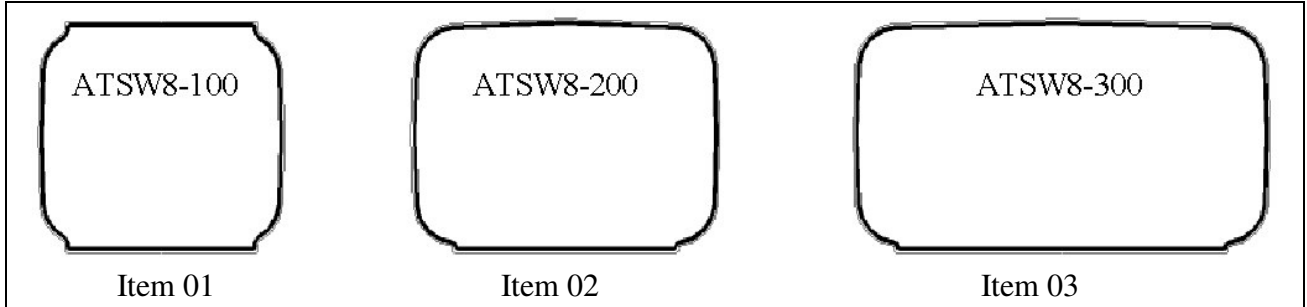

Figure 2.1

Liner applicability for Cessna Model 208, Kit No. ATSW8

Item	Qty	Part Number	Appears on Fig:
02	3	ATSW8-200	2.1,2.2
03	2	ATSW8-300	2.1,2.2

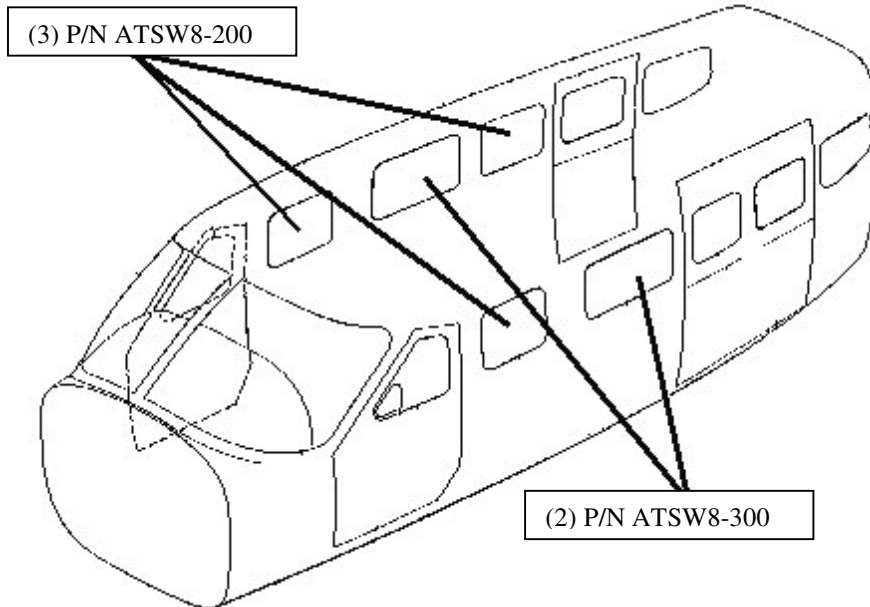

Figure 2.2

Liner applicability for Cessna Model 208B, Kit No. ATSW8-B

Item	Qty	Part Number	Appears on Fig:
01	2	ATSW8-100	2.1,2.3
02	7	ATSW8-200	2.1,2.3

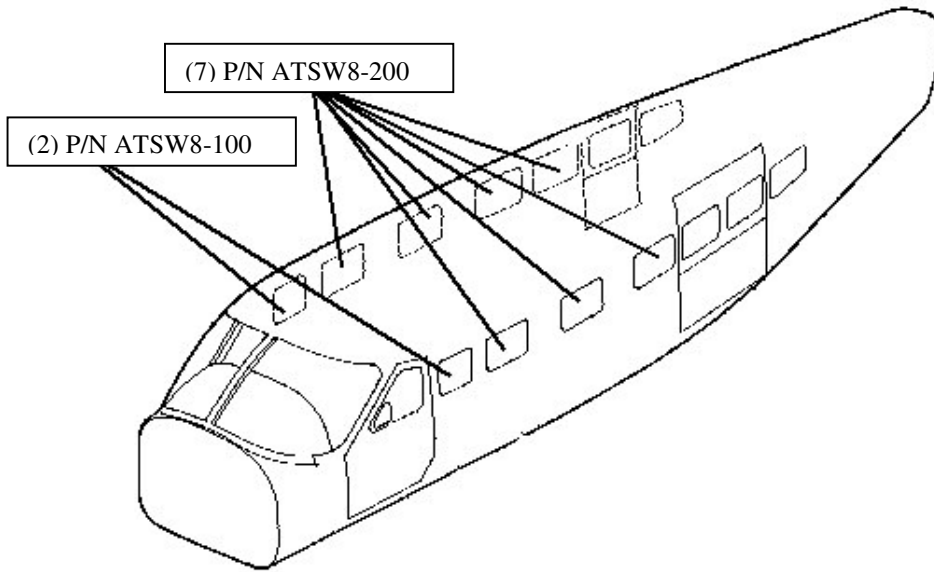

Figure 2.3