

Aero Twin, Inc. Double Place Folding Seat, P/N ATFS2-01
for
Cessna Model 208, 208B Caravan Aircraft

**INSTRUCTIONS FOR CONTINUED
AIRWORTHINESS**

Maintenance Manual
Airworthiness Limitations
Illustrated Parts List

FAA/DAS Approved:

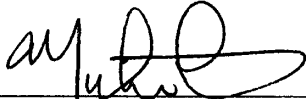

DAS Coordinator
Designated Alteration Station DAS-01-AK
Anchorage, Alaska

FAA/DAS Approved:

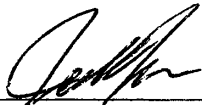

DAS Airworthiness Inspector
Designated Alteration Station DAS-01-AK
Anchorage, Alaska

Date: July 31, 1996

LOG OF REVISIONS			
REVISIONS		PAGES REVISED AND DESCRIPTION OF REVISIONS	APPROVAL SIGNATURE
NO.	DATE		
--	07/31/96	Original Issue	
A	10/01/96	Pages 2, 17 & 22; Pages revised in accordance with ECO-AT-46	
B	06/29/99	Pages 2, 17, 19, 21, and 22; Pages revised in accordance with ECO-AT54	
C	12/15/99	Pages 2, 7, & 16-22; Revised in accordance with ECO AT-56	

Table of Contents

Section	Page
Log of Revisions.....	2
Table of Contents	3
1.0 Maintenance Manual	4
1.1 Description.....	4
1.2 Installation/Removal.....	6
1.3 Storage.....	8
1.4 Weight and Balance.....	8
1.5 Maintenance Instructions	11
2.0 Airworthiness Limitations.....	15
3.0 Illustrated Parts List.....	17
3.1 Complete Parts List	17
3.2 Upper & Lower Arm Assemblies	18
3.3 Back Rest Cover and Upper Arm Installation	19
3.4 Seat Back, Lap Belt, and Harness Installation	20
3.5 Seat Bottom Hardware & Lower Arm Installation	21
3.6 Seat Bottom Cover & Foot Installation	22

1.0 Maintenance Manual

Aero Twin, Inc. Double Place Folding Seat P/N ATFS2-01

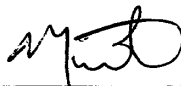
1.1 Description

The Aero Twin double place folding seat for the Cessna 208 Caravan is designed for quick and easy installation and removal, and for compact stowage when not in use.

The basic structure of the seat is a 4130 steel tube welded frame. The seat back and legs fold for storage. Five diagonal arms, each hinged at one end and equipped with a quick-release fitting at the other, provide primary structural support for the installed seat. Optional armrests, when installed, are integral with the upper diagonal arms. The seat pan is rubber-impregnated high-strength fabric attached to the seat frame using sheet-metal screws. The seat back cover is of the same material; it slides over the seat back frame and is secured with nylon straps. Each occupant's restraint is provided by a lap belt and single diagonal shoulder harness, all attached to the seat frame. The seat is equipped with six identical anti-rattle type track fittings that engage the standard Caravan seat tracks. A one-piece padded upholstery cover is supplied with each seat; this slides over the seat frame and is secured with hook-and-loop strips. The seat can be used without the upholstery cover if desired. The seat is identified by a data plate permanently attached to the forward leg cross-member. The data plate lists the part number, serial number, and date of manufacture of the seat.

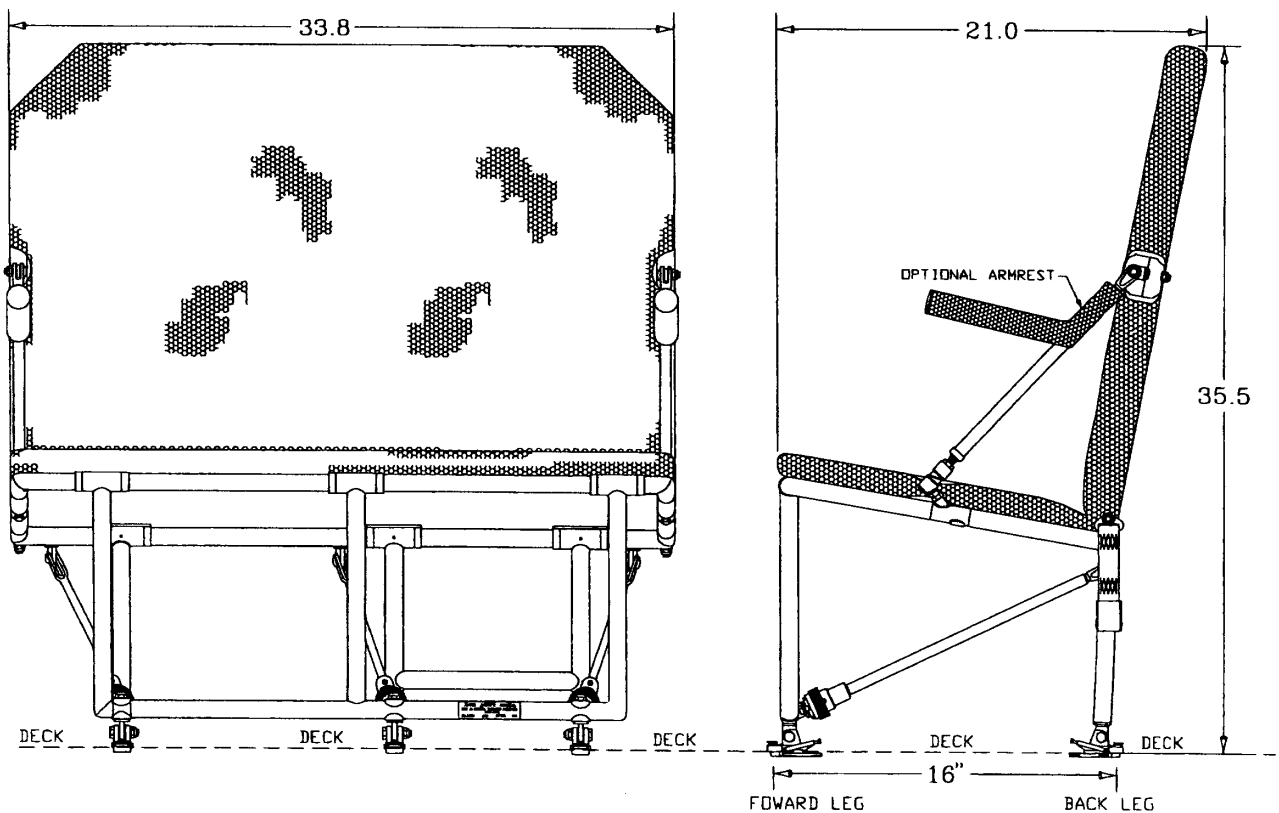

Figure 1.1.1 Basic Seat Dimensions

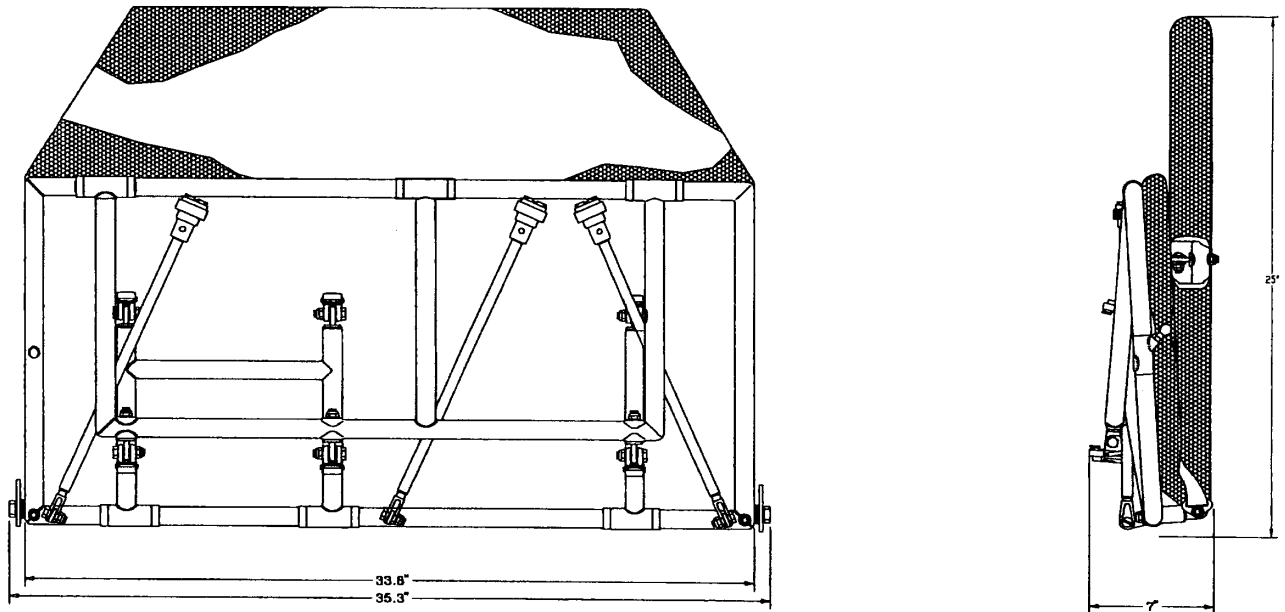

Figure 1.1.2 Folded Seat Dimensions

1.2 Installation / Removal

NOTE: This seat is certified for forward-facing installation only.

This section describes general installation procedures; for information on standard or non-standard seat locations and corresponding weight and balance data, see Section 1.4.

1.2.1 Setup and Installation:

1. Unfold forward leg and lower diagonal arms. On each quick-release fitting (item -104), push in the retaining pin and retract the locking ring (see detail in Figure 1.2.1). Position the diagonal arms to align fittings with studs (item -109) on forward leg. Push forward leg back to engage studs in fittings, then extend locking rings to close jaws.

Be sure jaws close completely and retaining pins pop out to the extended (locked) position - Failure to properly engage studs and lock fittings could result in seat collapse.

2. Unfold seat back and upper diagonal arms. Position the arms so the quick-release fittings (item -106) are over the corresponding studs (item -113) on the seat frame. Retract the spring-loaded collar on one fitting, push the fitting onto the stud, then release the collar. Repeat for the remaining arm.

Be sure the collars extend completely and the studs are properly captured in the fittings - failure to properly engage studs could result in seat collapse.

3. Unfold rear leg and position the seat over the seat tracks at the desired fuselage station. Drop the forward feet into the tracks (locking lugs must be in the retracted position), slide forward or aft 1/2 inch, and push the locking lugs down to lock the forward feet into the track.
4. Extend the rear legs afterward to the built-in rotation stops, then move legs forward until aft feet can drop into the tracks. Slide feet aft 1/2 inch and push locking lugs down to lock feet in track. Locking lugs of rear feet should be 16 inches (16 track positions) aft of forward feet locking lugs.
5. The feet are equipped with anti-rattle devices. Use is optional. To use the anti-rattle feature, tighten the screw in the anti-rattle device until the stirrup is drawn snug against the seat track.
6. If optional armrests are installed, rotate armrest into position and allow armrest sleeve to drop into position over the pin.
7. Update aircraft empty weight and balance to account for seat installation (see Section 1.4).

1.2.2 Removal / Breakdown:

1. Release anti-rattle feature on each of six feet (if feature is utilized).
1. Lift the rear feet locking lugs (a tool designed for this purpose is supplied with the seat; additional tools are available from Aero Twin, Inc.). Slide the feet forward 1/2 inch and lift the feet from the track.
2. Repeat step 1 for the forward feet. Remove seat from tracks.
3. Push in the retaining pins and retract the locking rings of the lower diagonal arm quick-release fittings. Disengage the forward leg studs from the fittings.

4. Fold the rear legs up, then the forward legs. Fold the arms into position alongside the forward legs.
5. Retract the spring-loaded collar on the quick release fitting on one of the upper diagonal arms and disengage the fitting from the stud on the seat frame. Repeat for the other arm.
6. If the optional armrests are installed, lift each armrest to disengage from it's retaining pin, then rotate inward.
7. Rotate and fold the upper arms inward across the seat back - note that the eyebolts in the seat back, to which the arms are attached, rotate in their bushings to accomplish this. The seat will fold best when the arms are positioned so that they do not cross each other.
8. Fold the seat back down.

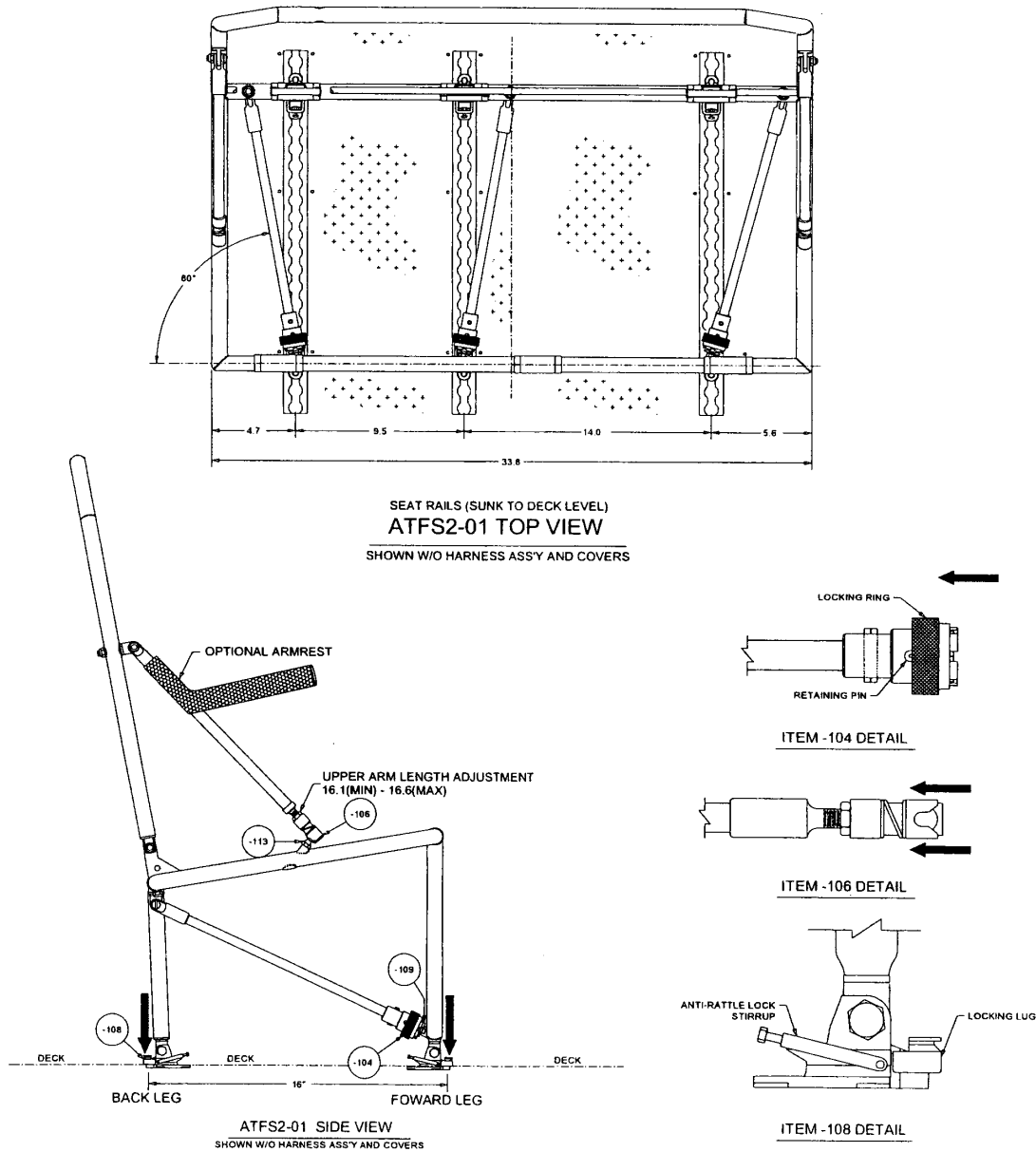

Figure 1.2.1 Seat Installation

A protective storage bag is provided with each seat. For long-term storage it is recommended that the seat be placed in its protective bag. During storage the seats should be kept in a dry location away from any direct heat source.

The seats can be stacked up to four-deep in storage. Do not stack more than 100 lb. on top of a folded seat.

Prior to installing a seat which has been in storage for an extended period, inspect and lubricate the seat in accordance with a 400 hr/Annual inspection.

1.4 Weight and Balance

When seats are installed or removed, the aircraft empty weight and balance must be updated to reflect the configuration change. Weight and balance data for the standard Aero Twin 8-place seating configuration is provided in section 1.4.2. For alternate seating configurations, see section 1.4.3.

1.4.1 General:

To facilitate locating fuselage stations in the cabin, Model 208B aircraft have single digit numbers (e.g. 6, 8, 0, etc.) on the seat tracks. The numbers 6, 8, 0, etc. refer to fuselage stations 160, 180, 200, etc. Where these reference numbers do not exist or are unreadable, the forward face of the raised aft cargo floor can be used as a reference. This face is located at station 284 in the Model 208, or at station 332 in the Model 208B.

1.4.2 Standard 8-Place Seating Configuration:

The standard 8-place seating configuration includes three double place seats located on either the right or the left side of the cabin (plus pilot and front-seat passenger). In this configuration the passenger seats are installed with the front-leg locking lugs at the fuselage stations shown in Figure 1.4.1. Some Model 208 Caravans have an "O" code marking stamped on the cabin seat tracks to indicate the correct locations of the seat forward feet for each commuter seat. These "O's" only pertain to the configuration with the double seats placed on the right hand side of the cabin.

Total weight, arm, and moment of three Aero Twin double place folding seats installed in the standard 8-place configuration is as shown in the following table.

**Double Place Folding Seats Weight and Balance Data for
Standard 8-Place Seating Configurations
(Three Aero Twin Double Place Folding Seats)**

Model	Total Weight (lb.)*		Arm (in)	Moment/1000	
	w/o Armrest	with Armrest		w/o Armrest	with Armrest
208	108	115.5	202	21.8	23.3
208B	108	115.5	210	22.7	24.3

*If upholstery covers are removed, subtract 18 lb. from weights and recalculate moments (change in moment arm is negligible).

1.4.3 Alternate Seating Configurations:

When installing Aero Twin double place folding seats in a configuration other than the standard configuration, the effect on aircraft empty weight and moment must be determined for that configuration. Individual seat weights are as shown below:

- Aero Twin, Inc. Double Place Folding Seat**
 Upholstery Cover Installed, w/o Armrests: 36 lb.
 Upholstery Cover Removed, w/o Armrests: 30 lb.
 Upholstery Cover Installed, with Armrests: 38.5 lb.
 Upholstery Cover Removed, with Armrests: 32.5 lb.

Individual Aero Twin Double Place Folding Seat center of gravity location is 10.5 inches aft of the forward feet locking lugs.

For any arbitrary seating configuration, the weight, arm, and moment of the complete double place seat installation can be found as follows (method assumes all installed seats are the same) :

1. Record the fuselage station where the forward feet locking lugs of each installed seat are located (see sub-section 1.4.1 above).
2. Add all the recorded fuselage stations for each seat, then divide the sum by the number of seats. Add 10.5 to the quotient for the seats. The result is the arm of the complete seat installation.
3. Multiply the number of seats by the appropriate individual seat weight. The result is the total weight of the seat installation.
4. Multiply the weight by the arm to arrive at the total moment. Divide the moment by 1000 to incorporate with the basic aircraft weight and balance data.

For Crew and Passenger weight and balance information for the standard commuter configurations, please refer to the Weight and Moment Tables in the Model 208 and 208B Information Manuals.

Note: When seats are installed in a non-standard configuration, the pilot or operator must be informed of actual seat locations so that passenger loading data can be correctly calculated.

Figure 1.4.1. Standard Configuration Seat Locations

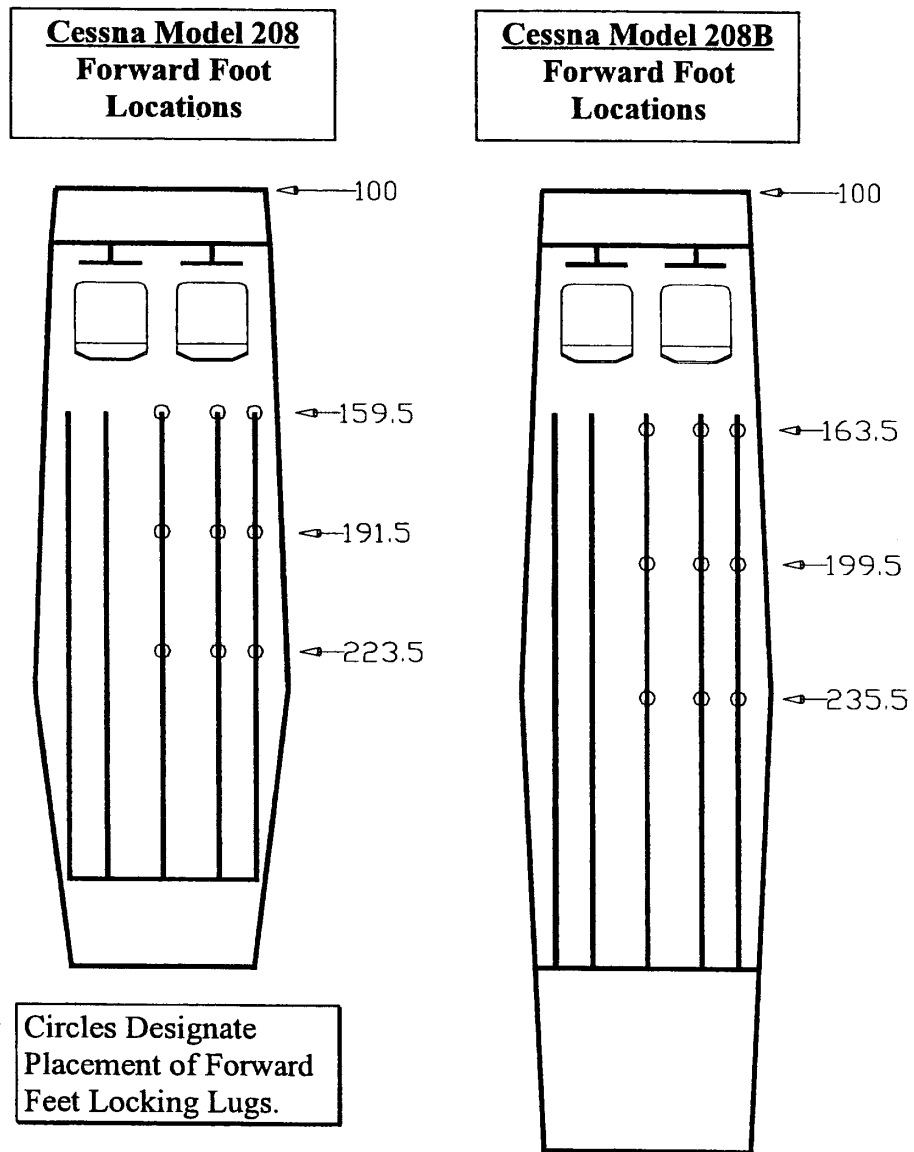

1.5 Maintenance Instructions

1.5.1 General:

The Aero Twin Double Place Folding Seat is designed to be highly durable and fairly maintenance free. However, a maintenance program has been established, in accordance with Appendix G of FAR 23, to assure the continued airworthiness of the seats. Adherence to the established plan is mandatory and records of performance of required inspections and maintenance must be maintained. See Section 2.0, Airworthiness Limitations, for required maintenance items and intervals.

1.5.2 Cleaning:

1.5.2.1 Upholstery:

- For general dust and light dry soiling, vacuum upholstery thoroughly, and or brush with a clean stiff bristle brush. Avoid beating fabric as this can hasten wear and does not effectively clean the upholstery. Use of commercially available upholstery shampoo will remove most soil encountered in normal service. Follow product directions.
- For oil or grease stains, solvent-type cleaning agents can be effective. Test a small inconspicuous area of the fabric first. Use solvent-type agents sparingly, without saturating fabric. Apply with a clean soft cloth and work from the edge of the stain towards the center to avoid spreading. Observe appropriate safety precautions when using any solvent agent.
- For heavy, saturating stains (coffee, vomit, etc.) the upholstery cover should be removed and commercially dry-cleaned.

1.5.2.2 Herculite fabric (seat pan and seat back cover):

Clean the Herculite fabric components using mild soap and water solution or a commercial vinyl cleaner. For heavy grease or oil stains, a diluted solution of Simple Green or equivalent cleaning solution can be used. Avoid excessive wetting of the fabric when installed on the seat, as moisture can collect between the fabric and tube structure and promote corrosion.

1.5.2.3 Metal Parts:

Moisten a clean soft cloth with a solvent-type cleaner or undiluted Simple Green or equivalent; thoroughly wipe metal parts completely clean. Wipe dry with a clean dry cloth. After heavy cleaning over or near lubricated joints, relubricate as appropriate.

1.5.3 Lubrication and Corrosion Prevention:

The hinged leg connections to the seat frame and the sliding armrest sleeve on the upper diagonal arms (when optional armrests are installed) are areas that must be kept well lubricated and protected from moisture. *Corrosion X™* is a product that is well suited to this dual purpose. This product is available from Aero Twin, Inc., or your local aviation supplier. Other commercial products are available that will perform well. WD-40 is not recommended, as its moisture displacement properties are inadequate.

The required maintenance procedures for the seat include lubrication and internal treatment of the steel tubes at specific intervals. The seat should also be lubricated if it is subjected to heavy moisture for any reason, or after thorough cleaning of the metal frame.

- To lubricate the rotating and sliding joints, spray lubricant into the joint while rotating or sliding the fitting (avoid overspray on the upholstery cover by first pulling the cover back from the joint). Wipe off all excess lubricant with a clean dry cloth.
- To internally treat the steel tubes, the upholstery cover and Herculite fabric seat pan and seat back cover should be removed. Using a small nozzle, spray *Corrosion X™* (or equivalent) into all available holes. Allow the frame to sit for several minutes to allow excess to drain as it may, then wipe off all external surfaces with a clean, dry cloth. Reassemble seat.

If the painted surface of the steel tube structure is marred in service or during handling, the affected area should be repainted to prevent corrosion. See instructions in section 1.5.5.3.

1.5.4 Disassembly / Assembly:

1.5.4.1 Disassembly:

- To remove the padded upholstery cover, the shoulder harnesses must be removed. Access to the clevis bolt head is through the opening in the upholstery cover at the bottom of the seat back. When optional armrests are installed, the upper diagonal arms must also be removed to remove the upholstery cover (disconnect from the eyebolts in the seat back frame). Pull the cover bottom free from the hook-and-loop strips on the seat pan, then slide the cover up and off the seat back.
- To remove the Herculite seat back cover, loosen and release the strap buckles on the aft side of the seat, then slide the cover off of the seat back frame.
- To remove the Herculite seat pan, remove the sheet metal screws from the underside of the seat frame.
- Disassembly of the seat frame is straightforward, as all connections utilize standard aircraft hardware.

1.5.4.2 Assembly:

Refer to the Illustrated Parts List when reassembling the seat frame.

Replace self-locking type nuts with new hardware when reassembling seat.

Any time the Herculite seat pan is removed, use new screws for reinstallation.

Use standard torques except as follows:

- The nuts on the seat back hinge bolts, which retain the lap belts, should be snug but not over-tight to allow rotation of the seat back and the lap belt fittings.
- The nuts on the clevis bolts at the upper ends of the five diagonal arms, and the nuts that retain the four eyebolts to which the arms attach, should be snug but not over-tight to allow rotation of the arms for folding.

- The nuts and bolts which attach the feet (seat track fittings) to the eyebolts at six locations should not be tightened so much as to cause distortion of the cast lugs on the fitting.

Remember that the padded upholstery cover, when utilized, must be installed prior to installation of the shoulder harnesses and armrests (when armrests are not present, the upper diagonal arms can be installed prior to the cover).

1.5.4.3 Adjustments:

- Upper Diagonal Arms: The length of these is adjustable by turning the lower end fitting in or out on the integral stud. Maximum acceptable length is 16.6 inches - **do not exceed this length when making adjustments to these assemblies.**
- Lower Diagonal Arms: These members are not adjustable, but minor adjustments can be made at the stud (item -109) in the forward leg assembly. Maximum allowable extension is that which produces a gap of 0.20 inch between the top of the welded nut on the leg and the bottom of the hex-head on the stud - **do not exceed this measurement.**
- **Do not** attempt to adjust the height of the rear legs by turning out the eyebolts to which the feet are attached. Need for such adjustment indicates warpage elsewhere in the seat frame which should be corrected.

1.5.5 Repair:

1.5.5.1 Hardware Replacement:

Hardware and fittings used throughout the seat are aircraft standard. Hardware should be replaced if corroded, damaged, or excessively worn. Replace self-locking type nuts with new hardware when reassembling seat. Do not substitute hardware - refer to the Illustrated Parts List for correct part numbers. If you encounter difficulty procuring replacement hardware or fittings, contact Aero Twin, Inc. at (907) 274-6166. Refer to previous section for assembly information.

1.5.5.2 Steel Tube Frame:

The seat frame is of welded 4130 steel tube (MIL-T-6736) construction and can be repaired in accordance with the procedures prescribed in AC 43.13-1A Chapter 2, Section 2 (see note below). Any welded repair should be preceded by stripping the paint from the affected area, and followed by repainting to prevent corrosion (see following section). Care should be taken to avoid warping or drawing when performing welding operations on the seat. Excessive warping can result in difficult assembly and installation, and detrimental preloads in an installed seat.

NOTE: Lower Diagonal arms, P/N ATFS-85 and Upper diagonal arms, P/N ATFS-95, are not eligible for repair. If these parts are found to be bent or cracked, they must be discarded and replaced. Refer to Airworthiness Limitations in Section 2.0 of this manual.

1.5.5.3 Painted Surfaces:

Painted steel surfaces should be maintained and refinished as required to prevent corrosion. When refinishing is required, lightly sand the affected area using fine sandpaper or an

abrasive pad (such as 3M *Scotch-Brite*[™]). Polish out minor surface nicks or scratches where present. Clean the area thoroughly with a clean cloth wetted with non-petroleum-based solvent to remove any residual oils and dust. Apply a zinc-chromate or equivalent primer coat, then a matching color coat of quality enamel or epoxy-type paint. Follow manufacturer's instructions in preparing and applying primer and color coats.

1.5.5.4 Fabric:

- **Herculite Components:** These components are subject to mandatory replacement at ten-year intervals, but should be replaced when found to be excessively worn, frayed, or torn. Open seams can be restitched using nylon thread.
- **Upholstery:** Restitch open seams using nylon thread. Small tears can be drawn closed and sewn. Extensive damage usually justifies replacement of the upholstery cover.

1.5.5.5 Restraint Belts:

Worn, frayed, cut, or otherwise damaged belt assemblies should be replaced or remanufactured by a qualified repair station. Any belt assembly that is found to be missing its manufacturer's data patch must be considered unairworthy and must be replaced.

2.0 Airworthiness Limitations

Aero Twin, Inc. Double Place Folding Seat P/N ATFS2-01

The Airworthiness Limitations section is FAA/DAS approved and specifies maintenance required under paragraphs 43.16 and 91.403(c) of the Federal Aviation Regulations unless an alternative program has been FAA approved.

This section describes required inspection, maintenance, and replacement items. When repairs are deemed necessary, follow accepted standard practices and/or specific maintenance instructions in Section 1.5 of this manual.

This section constitutes Component Airworthiness Limitations which apply to the seat only.

2.1 Scheduled Inspections and Maintenance:

Note: First inspection should be accomplished at next aircraft inspection so that subsequent inspections coincide.

2.1.1 400 hour or Annual Inspection:

Remove padded upholstery cover.

Inspect steel tube frame:

 Tubes for bends, dents, corrosion, or other defects.

 Welded areas for cracks or other defects.

 Finish for scratches, abrasion, etc.

Inspect hardware and fittings:

 Hardware for security and condition.

 Quick-release fittings for proper operation and condition.

 Feet (track fittings) for proper operation, security, and condition.

Inspect Herculite fabric (seat pan and seat back cover):

 Fabric for wear, fraying, tearing, or other defects

 Attachment screws (seat pan) for security

 Straps and buckles (seat back) for condition and tautness

Inspect restraint system (lap belts and harnesses):

 Webbing for cuts, fraying, or other defects.

 End fittings for security and condition.

 Buckles for proper operation.

 Data patches (must be present and legible).

Inspect overall seat assembly and upholstery for cleanliness and general airworthiness.

Lubricate all rotating and sliding parts fittings (Corrosion X™ or equivalent).

Reinstall padded upholstery cover.

FAA/DAS Approved:

DAS-01-AK

2.1.2 Five-Year Inspection:

Remove padded upholstery cover.

Remove Herculite seat pan and seat back cover.

Inspect steel tube frame:

All welded joints using a 10X glass for cracks.

(Strip paint from area around any apparent crack and re-inspect).

Treat all tubing internally with corrosion preventative (*Corrosion X™* or equivalent).

Complete all items for a **400 Hour / Annual Inspection**.

Reinstall seat pan using new screws; reinstall seat back cover and upholstery cover.

2.1.3 Ten-Year Inspection:

Remove padded upholstery cover.

Remove Herculite seat pan and seat back cover and discard.

Disassemble seat frame.

Strip paint from all welded joints and inspect using a 10X glass.

Complete all items for a **5-Year Inspection**.

Repaint seat frame components.

Reassemble seat frame using new hardware.

Install NEW Herculite seat pan and seat back cover (P/N's ATFS2-06 and ATFS2-07A).

Reinstall padded upholstery cover.

-----**End of Section 2.0 Airworthiness Limitations**-----

FAA/DAS Approved:



DAS-01-AK

3.0 Illustrated Parts List

3.1 Complete Parts List: ATFS2-01

Item	Qty	Part Number	Description	Appears on Fig:
-02	3	ATFS-02A	Complete Lower Arm Assembly	3.5
-03	2	ATFS-03A	Complete Upper Arm Assembly	3.3
-04	1	ATFS2-04	Seat Back Weldment	3.3
-05	1	ATFS2-05 (L or R)	Seat Bottom Weldment	3.5
-06	1	ATFS2-06	Back Rest Cover Assembly	3.3
-07	1	ATFS2-07A (L or R)	Seat Bottom Cover Assembly	3.6
-62	6	ATFS-62H	Eye Bolt	3.5, 3.6
-85	3	ATFS-85A	Lower Arm Weldment	3.2
-95	2	ATFS-95A	Upper Arm Weldment	3.2
-95 alt.	(2)	ATFSAR-A	Upper Arm w/Armrest	3.2
-100	AR	AN960-516L	Washer	3.3, 3.4, 3.5, 3.6
-101	25	MS20364-524	Nut	3.3, 3.4, 3.5, 3.6
-102	5	AN25-14	Bolt	3.3, 3.5
-103	3	AN5-11A	Bolt	3.4
-104	3	MS22034-1	Retainer	3.2
-105	2	AN316-6R	Nut	3.2
-106	2	SS-1004	Retainer (Sub-Assembly)	3.2
-107	6	AN5-10A	Bolt	3.6
-108	6	40566-14	Retainer (Foot; Track Fitting)	3.6
-109	3	ATFS-109	Fitting (stud)	3.6
-110	3	NAS561P8-16	Pin	3.2
-111	2	AN45-12A or ATFS-62H	Eye Bolt	3.3
-112	2	MS20364-428	Nut	3.4
-113	2	ATFS-113	Ball Stud	3.5
-117	3	AN5-7A	Bolt	3.4
-119	AR	AN960-516	Washer	3.4
-120	2	AN24-25A	Bolt	3.4
-121	2	NAS77-4-10	Shoulder Fitting (Flange Bushing)	3.4
-122	AR	AN960-416	Washer	3.4
-123	2	C1500-2	Seat Belt (2 Piece Assy.)	3.4
-131	37	S1021A6-8 or MS51863-23C	Screw	3.6
-140	2	ATFS-140	Shoulder Harness Assembly	3.4
-153	2	ATFS-153	Extended Clasp	3.4
-154	1	AN5-13A	Bolt	3.4
Accessories:				
N/A	N/A	ATFS2-08	Padded Upholstery Cover	(not shown)
N/A	N/A	ATFS2-09	Storage Bag	(not shown)
N/A	N/A	AT-SRT-01	Removal Tool	(not shown)

Figure 3.1

3.2 UPPER AND LOWER ARM ASSEMBLIES

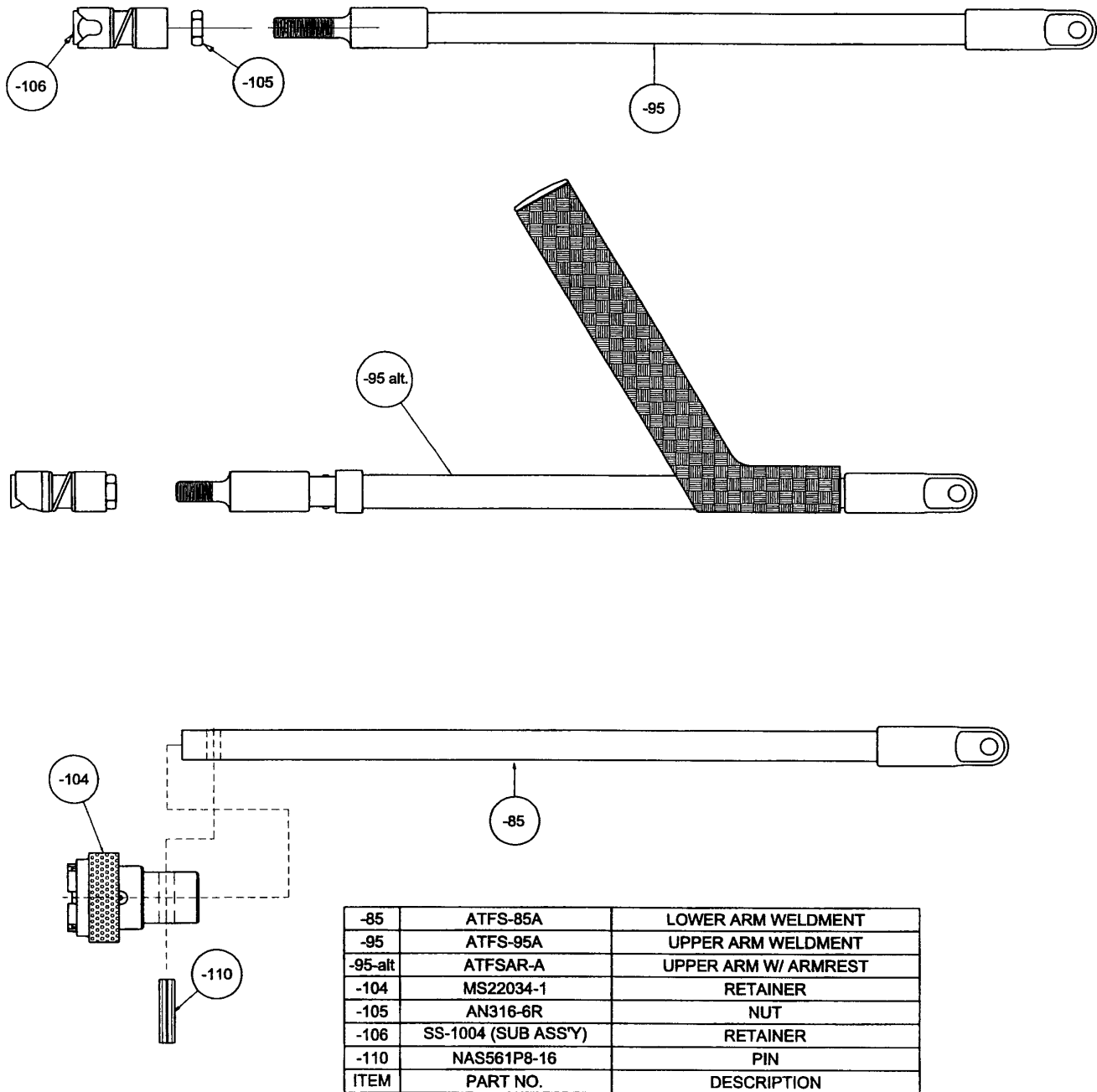
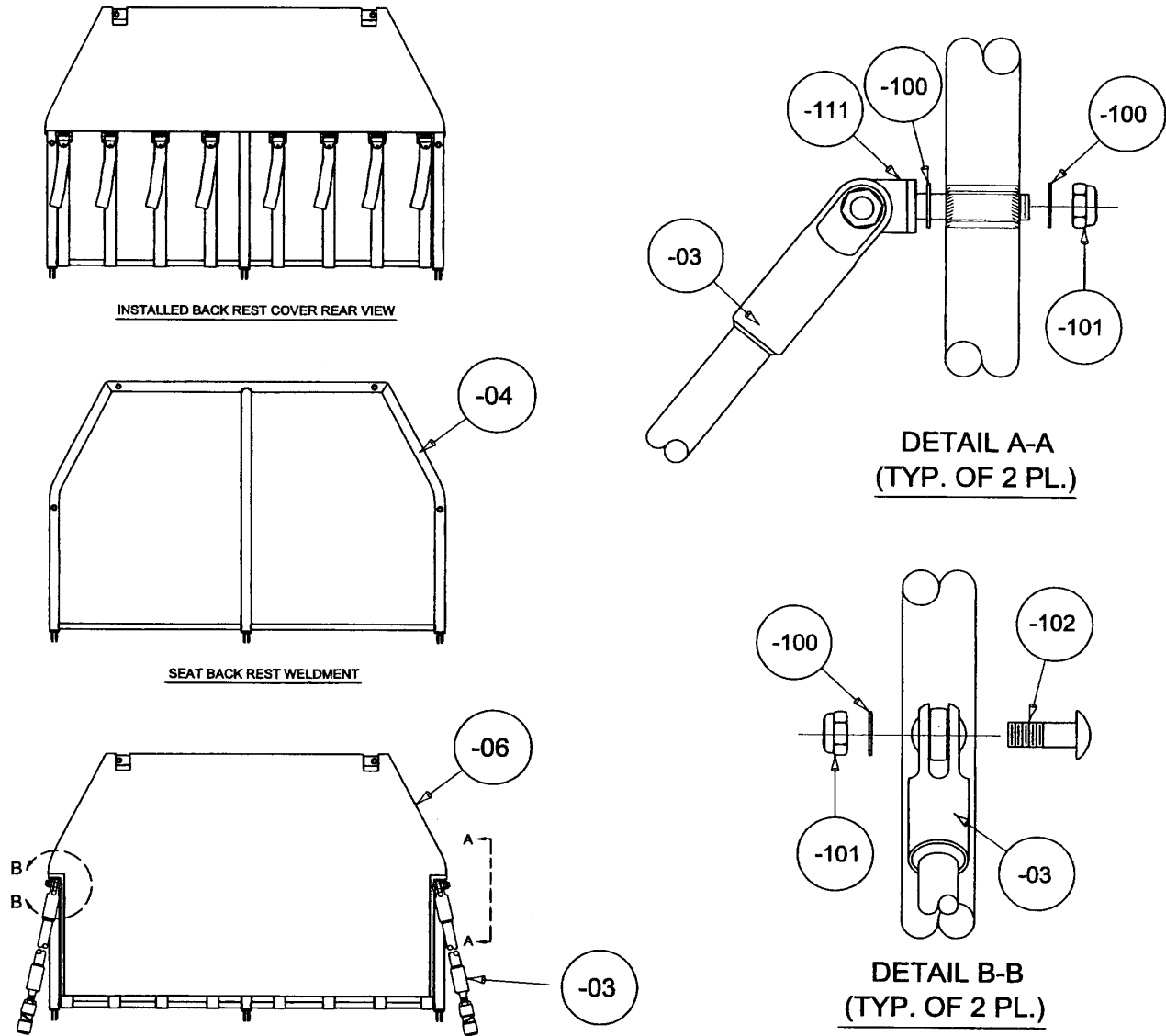

FIGURE 3.2

3.3 BACK REST COVER AND UPPER ARM INSTALLATION



-03	ATFS-03A	UPPER ARM ASSEMBLY
-04	ATFS2-04	SEAT BACK WELDMENT
-06	ATFS2-06	BACK REST COVER ASS'Y
-100	AN960-516(L)	WASHER
-101	MS20364-524	NUT
-102	AN25-14A	BOLT
-111	AN45-12A OR ATFS-62H	EYE BOLT
ITEM	PART NO.	DESCRIPTION

FIGURE 3.3

3.4 SEAT BACK, LAP BELT, AND HARNESS INSTALLATION

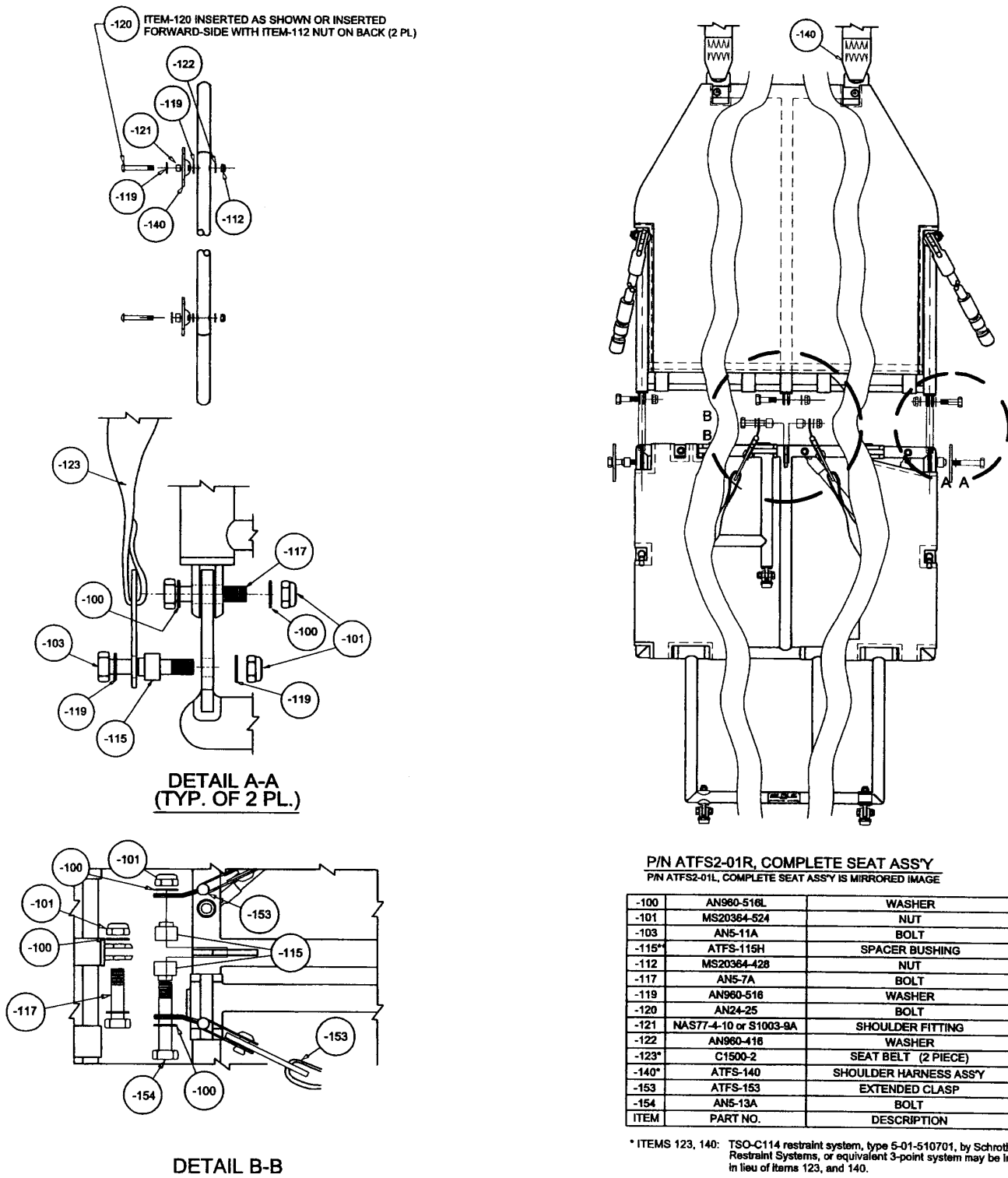

* ITEMS 123, 140: TSO-C114 restraint system, type 5-01-510701, by Schroth Restraint Systems, or equivalent 3-point system may be installed in lieu of items 123, and 140.

** ITEM 115: Items -100 and -119 may be substituted for each other and item -115 as required.

FIGURE 3.4

3.5 SEAT BOTTOM HARDWARE & LOWER ARM INSTALLATION

-02	ATFS-02A	COMPLETE LOWER ARM ASSY
-05	ATFS2-05	SEAT BOTTOM WELDMENT
-62	ATFS-62H	EYE BOLT
-100	AN960-516(L)	WASHER
-101	MS20364-524	NUT
-102	AN25-14A	BOLT
-113	ATFS-113	BALL STUD
ITEM	PART NO.	DESCRIPTION

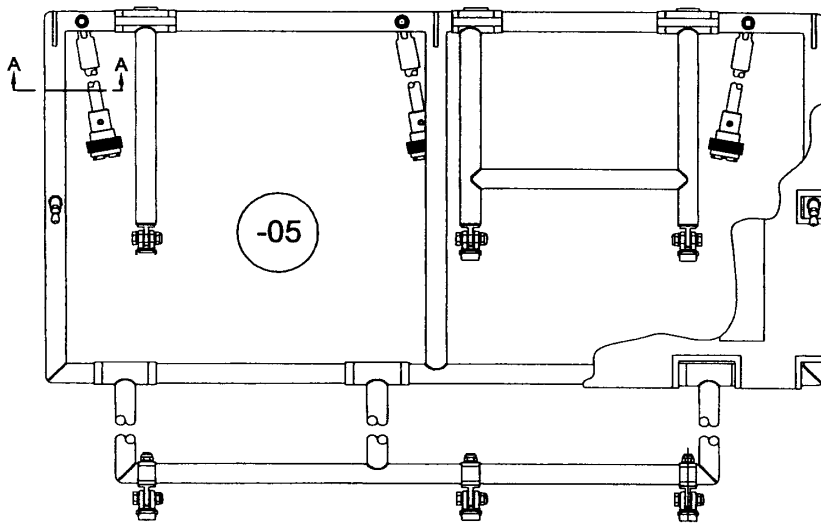

SEAT ASSEMBLY WELDMENT

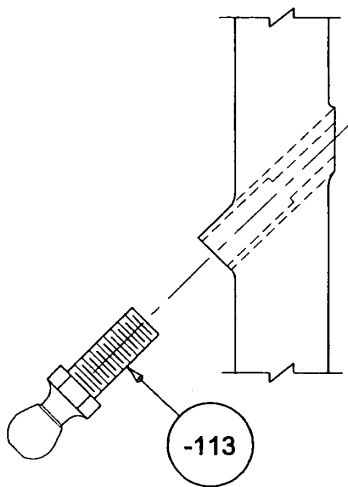

DETAIL B-B
(TYP. OF 2 PL.)

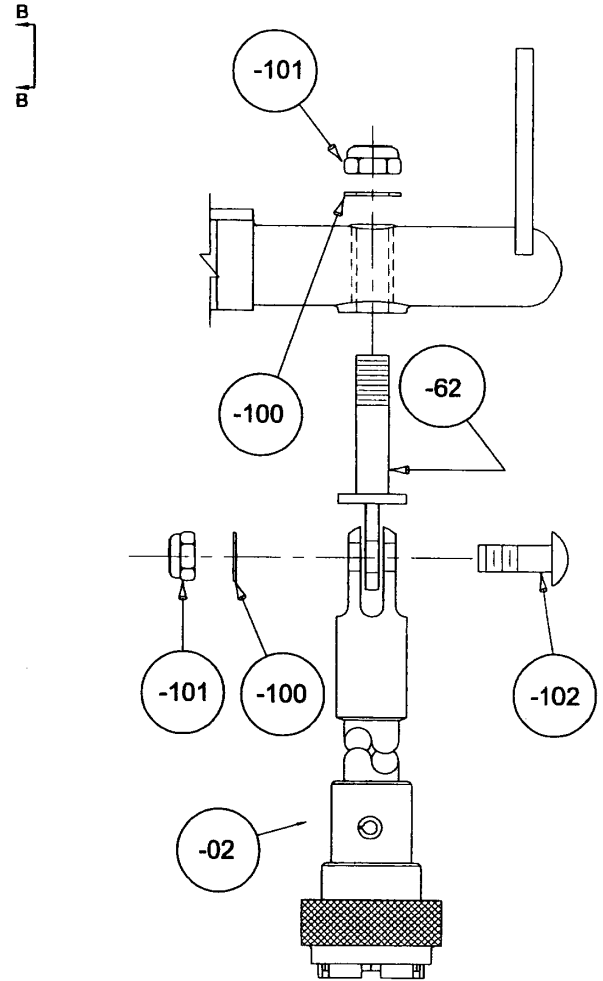

DETAIL A-A
(TYP. OF 2 PL.)

FIGURE 3.5

3.6 SEAT BOTTOM COVER AND FOOT INSTALLATION

-07	ATFS2-07A (L or R)	SEAT BOTTOM COVER ASS'Y
-62	ATFS-62H	EYE BOLT
-100	AN960-516L	WASHER
-101	MS20364-524	NUT
-107	AN5-10A	BOLT
-108	40566-14	RETAINER (FOOT)
-109	ATFS-109	FITTING
-131	S1021A6-8 or MS51863-23C	SCREW
ITEM	PART NO.	DESCRIPTION

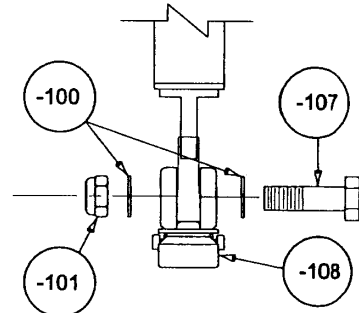

DETAIL A-A
(TYP. OF 2 PL.)

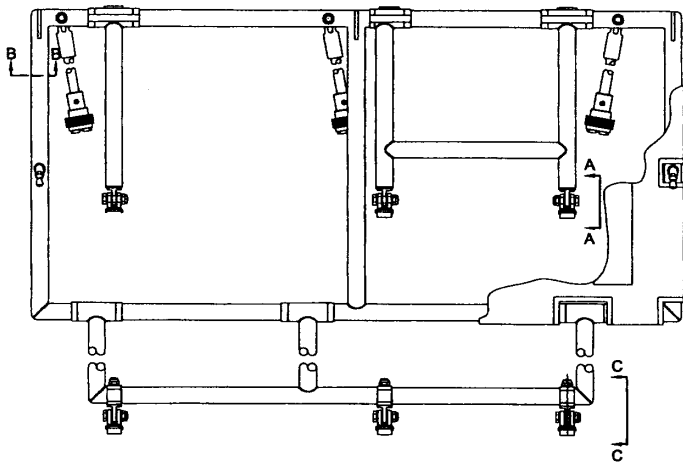

SEAT ASSEMBLY WELDMENT

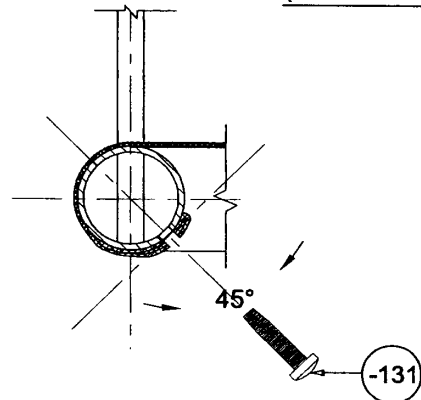

DETAIL B-B
(TYP. OF 2 PL.)

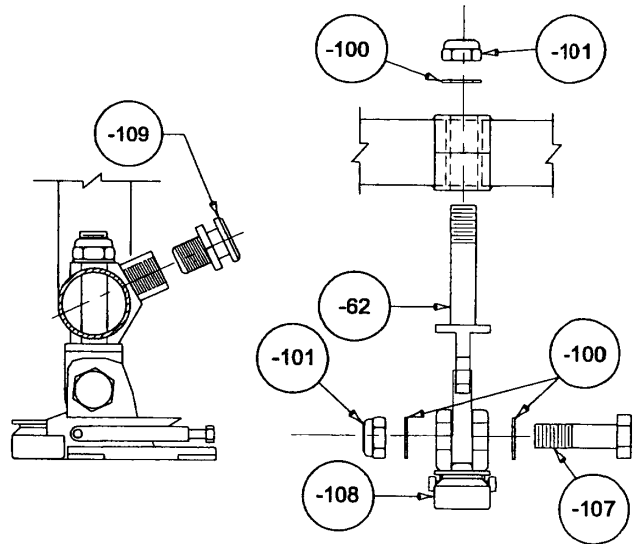
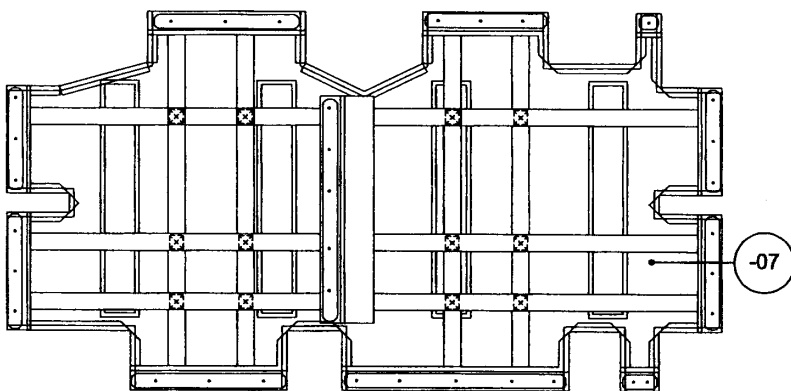

DETAIL C-C
(TYP. OF 2 PL.)

FIGURE 3.6