

Aero Twin, Inc. Rudder Gust Lock Kit No. AT-RL-1001
for
Cessna Model 208, 208A, 208B Caravan Aircraft

**INSTRUCTIONS FOR CONTINUED
AIRWORTHINESS**

Document No. AT-RL-1001-ICA

Maintenance Manual
FAA Approved Airworthiness Limitations
Illustrated Parts List

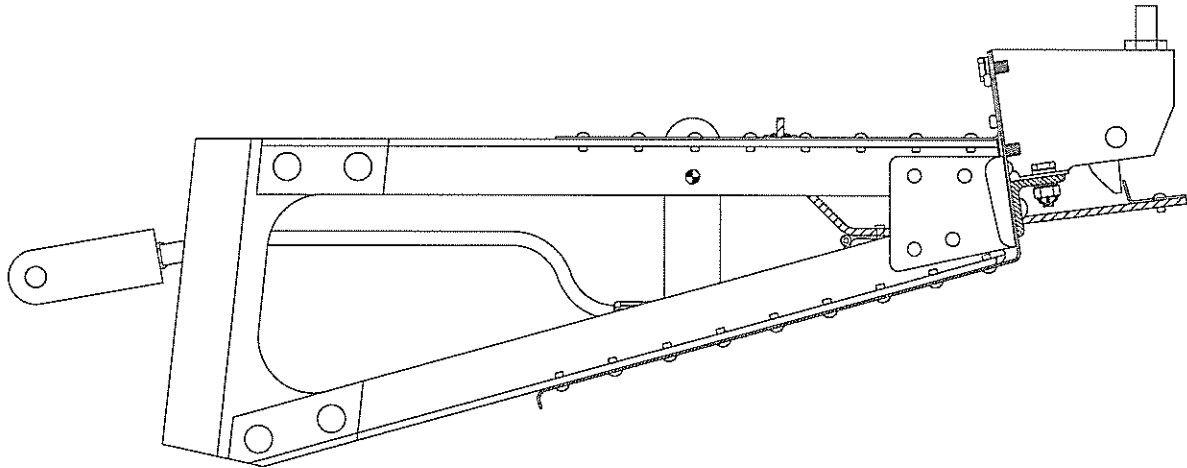

Approved: _____

Jason Kaplan
Director of Engineering
Aero Twin, Inc.

Date: June 23, 2011

Rev: H

LOG OF REVISIONS			
REVISIONS		PAGES REVISED AND DESCRIPTION OF REVISIONS	APPROVAL SIGNATURE
NO.	DATE		
--	09/01/88	Original Issue	--
A	06/22/90	Revised per ECO AT-09	--
B	03/20/92	Revised per ECO AT-21 (Rev B effective on kit S/N 156 and later, or upgrade)	--
C	01/25/93	Revised per ECO AT-23	--
D	06/15/99	All pages revised and reissued per ECO AT-53, dated June 15, 1999. Document No. AT-RL-1001-ICA assigned to this document.	--
E	01/19/01	Revised pages 2 & 10 per ECO AT-63	--
F	11/25/02	Revised per ECO AT-85	--
G	01/22/04	Revised per ECO AT-96	--
H	06/23/11	Revised per ECO AT-140	<i>Jason Kipler</i>

Table of Contents

Section/Paragraph	Page
Section 1.0 Maintenance Manual	4
1.1 Removal of tail stinger/fairing assembly	4
1.2 Removal of rudder lock assembly	4
1.3 Configuring aircraft for operation with rudder lock assembly removed.....	4
1.4 Reinstallation of rudder lock assembly.....	5
1.5 Detailed Functional Checks and Adjustments	6
1.6 Condition Inspection	7
1.7 General Operational Check	8
1.8 Weight and Balance.....	8
Section 2.0 Airworthiness Limitations.....	9
2.1 Scheduled Inspections and Maintenance.....	9
Section 3.0 Illustrated Parts List	10

1.0 Maintenance Manual

1.1 Removal of tail stinger/fairing assembly:

- (i): Disengage the rudder lock.
- (ii): Remove the rudder lock handle.
- (iii): Remove the cover plate.
- (iv): Remove the stinger/fairing assembly in accordance with the FAA approved Cessna 208 Series Maintenance Manual (D2075-13, dated September 2, 1986, or newer applicable revision).

1.2 Removal of rudder lock assembly:

- (i): Remove the tail stinger/fairing assembly in accordance with paragraph 1.1 of this document.
- (ii): Remove the bolt which secures the release linkage to the elevator control horn and elevator push rod.
- (iii): Remove the eight bolts (with nuts) that secure the assembly to the rear bulkhead.

NOTE: At this point the elevator is disconnected from the control system and the vertical fin attachment to the fuselage is incomplete; the aircraft should be appropriately tagged.

1.3 Configuring aircraft for operation with rudder lock assembly removed:

- (i): Remove the rudder lock assembly in accordance with paragraph 1.2 of this document.
 - (ii): Reattach the elevator push rod to the elevator control horn in accordance with the FAA approved Cessna 208 Series Maintenance Manual using the following hardware:
 - (1) AN4-13A bolt
 - (2) AN960-416L washer
 - (1) MS17825-4 Nut
 - (1) MS24665-134 cotter pin (new - do not reuse the old pin)
 - (2) NAS77-4-006 Flanged Bushing (these act as spacers)
- Torque nut to 65 to 80 inch pounds.
- (iii): Reinstall the eight bolts in the open holes in the rear bulkhead angles - use additional washers (AN960-10 or -10L) as required to account for the 0.081 inch thickness of the rudder lock assembly attach plates. DO NOT reuse any MS20365-1032A fiber-lock nut that can be fully run up finger-tight. Torque nuts to 20-25 inch-pounds.
 - (iv): Reinstall the tail stinger/fairing assembly in accordance with the FAA approved Cessna 208 Series Maintenance Manual. Install the rudder lock handle cover plate.
 - (v): Make log book entry stating that rudder lock assembly has been removed for service. Update aircraft weight and balance data using data given in paragraph 1.8 of this document.

1.4 Reinstallation of rudder lock assembly:

- (i): If the aircraft was operated with the rudder gust lock assembly removed, prepare for reinstallation as follows:
 - a) Remove the stinger/fairing assembly in accordance with the FAA approved Cessna 208 Series Maintenance Manual.
 - b) Remove the eight bolts and nuts from the rear bulkhead angles, where the rudder gust lock assembly was previously installed.
 - c) Disconnect the elevator pushrod from the elevator control arm.
- (ii): Attach the rudder lock assembly to the rear bulkhead angles using AN3-5A bolts, MS20365-1032A nuts, and AN960-10L washers (eight each). DO NOT reuse any MS20365-1032A fiber-lock nut that can be fully run up finger-tight. Torque nuts to 20-25 inch-pounds.
- (iii): Attach the rudder lock control linkage to the elevator push rod and control horn using the following hardware (refer to Figure 1):

- AN4-13A bolt
- AN960-416 washer
- MS17825-4 Nut
- MS24665-134 cotter pin (new - do not reuse the old pin)
- NAS77-4-006 Flange Bushing (2 each)

Torque nut to 65 to 80 inch pounds.

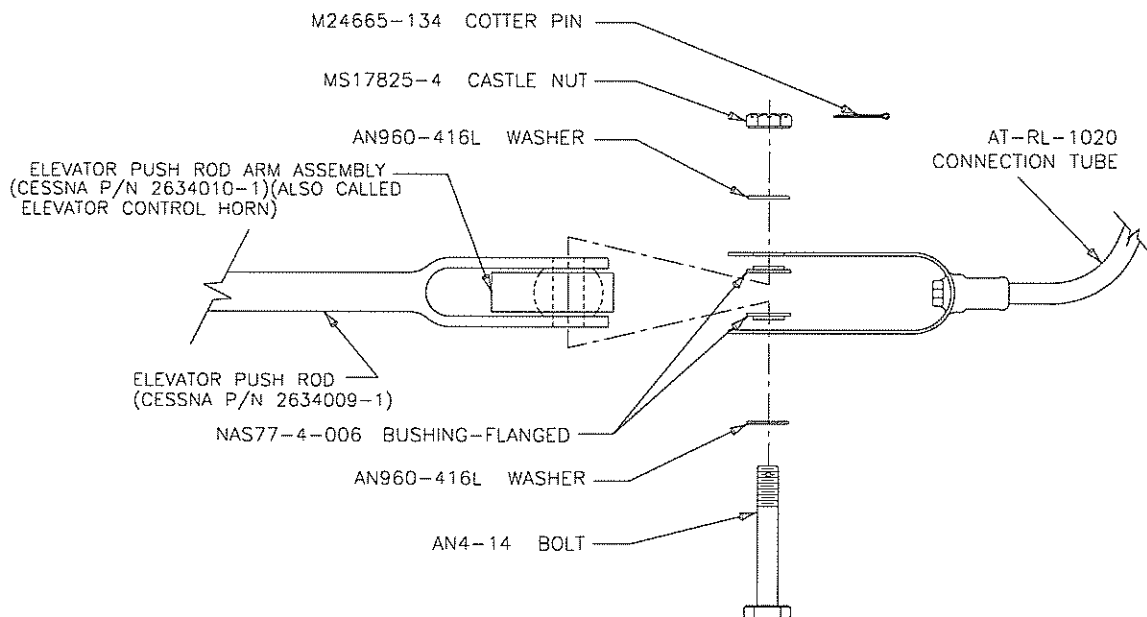

TORQUE -2 NUT 65 TO 80 IN/LBS. ENSURE CONTROL SYSTEM OPERATES NORMALLY WITHOUT BINDING OR INTERFERENCE PER APPLICABLE MAINTENANCE MANUAL.

Figure 1: Elevator Interconnect Hardware

- (iv): Perform functional checks described in paragraph 1.5 of this document. Make adjustments as required.

- (v): Reinstall the tail stinger/fairing assembly in accordance with the FAA approved Cessna 208 Series Maintenance Manual. Install the rudder lock handle cover plate. Install the control handle on the shaft.

1.5 Detailed Functional Checks and Adjustments:

- (i): Remove the tail stinger/fairing assembly in accordance with paragraph 1.1 of this document.
- (ii): Check control linkage travel and ensure it does not rub or bind. Ensure that a minimum 3/16 inch clearance exists between the rudder torque tube and the control linkage throughout the range of motion of the mechanism.
- (iii): Engage the elevator control lock in the cabin on the control yoke. Engage the rudder lock, using the control handle to raise the pin to the 'locked' position.
- (iv): Ensure release rod stop is 0.050 to 0.100 inch aft of the rudder lock cam follower (see Figure 2). This clearance determines the elevator angle at which the rudder lock releases. A clearance of 0.050 to 0.080 will cause the rudder lock to release at approximately 1 degree up elevator. Any required adjustment should be made as follows:
 - a) Disconnect the rod end located at the aft end of the connection tube from the lower end of the bell crank by removing the nut and bolt (AN3-7). Loosen the AN315-3R check nut that secures the rod end and turn the rod end in or out as required to provide proper clearance. At least four threads of the rod end must be engaged in the connection tube. When clearance is set, torque the check nut to 20 to 25 inch pounds, and reconnect the rod end to the bell crank; use a new cotter pin to secure the nut.
 - b) If the available adjustment at the rod end is insufficient, adjustment can be made at the pin eye at the forward end of the release rod. The two nuts which secure the pin eye to the bar can be run up or down the pin eye threads to produce the required clearance at the release rod stop. After adjustment torque the nuts to 10 to 15 inch pounds. Note that adjustments made here can affect the motion of the release rod so as to change the vertical clearance between the release rod stop and the lock body (see next step).
- (v): Check that there is at least a 1/4 inch of clearance between the top of the release rod stop and the bottom of the rudder lock body. If not, carefully bend the release rod (1"x1/8" aluminum bar) as required to provide adequate clearance
- (vi): Remove the elevator control lock and pull back on the yoke; the rudder lock should release when the elevator is between neutral and 4 degrees up. Make additional adjustments if required.
- (vii): Reinstall the tail stinger/fairing assembly in accordance with the FAA approved Cessna 208 Series Maintenance Manual. Install the rudder lock handle cover plate. Install the control handle on the shaft.

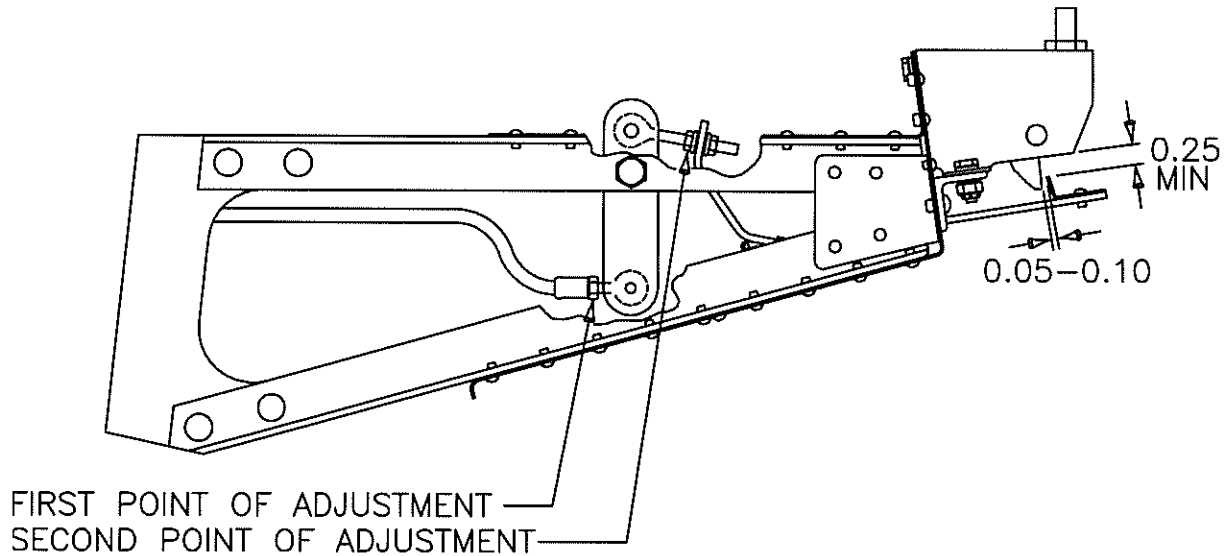

Figure 2: Measurements and Adjustments

1.6 Condition Inspection:

- (i): Remove the tail stinger/fairing assembly in accordance with paragraph 1.1 of this document.
- (ii): Closely inspect the entire system for cracks, loose rivets, corrosion, and general condition.
 - a) If any cracks are found the rudder lock system should be removed and returned to Aero Twin, Inc. for repair/replacement.
 - b) Loose rivets can be replaced following standard practices.
 - c) Light surface corrosion can be cleaned up and the affected area re-coated. Corroded hardware should be replaced.
- (iii): Check the release rod stop, P/N AT-RL-1007, for wear. If any part of the stop is worn to 0.030 inch or less thickness (from the original thickness of 0.040), remove the release rod stop and install a new one:

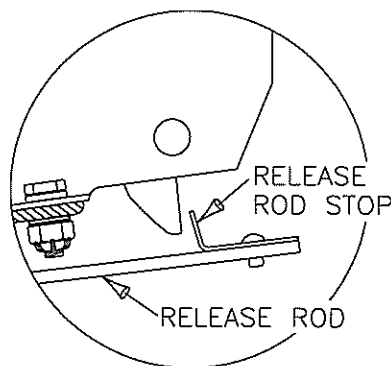

Figure 3: Release Rod Stop

- a) Positioning the elevator in the full down position moves the release rod fully aft for best access.
- b) Drill out the two rivets that secure the stop.
- c) Install a new rod stop using two MS20470AD4-6 rivets.
- d) Perform functional checks in accordance with paragraph 1.5 of this document.

Note: Wear of the release rod stop indicates that the rudder lock has not been routinely disengaged using the handle - that the pilots have been disengaging the rudder lock using the elevator safety connection. If such is the case, the pilots should review the normal procedures described in the flight manual supplement provided with the kit.

- (iv): Check the complete release linkage for signs of wear or rubbing. If the linkage exhibits excessive wear or sloppiness, the condition should be rectified by replacement of worn components, or by removing the entire rudder lock assembly and returning it to Aero Twin for service.
- (v): Check the condition of the rudder strike plate located at the bottom of the rudder. Replace if excessively worn or damaged. Follow standard sheet metal repair practices.
 - P/N AT-RL-1027: Strike Plate Assembly, Standard
 - P/N AT-RL-1030: Strike Plate Assembly, Sea Plane Rudder
- (vi): Thoroughly Rinse the rudder gust lock assembly and surrounding area with clear water. Apply a non-congealing corrosion block / lubrication product, such as *Corrosion-X™* (or equivalent), to the linkage and the entire lock body.
- (vii): Reinstall the tail stinger/fairing assembly in accordance with the FAA approved Cessna 208 Series Maintenance Manual. Install the rudder lock handle cover plate. Install the control handle on the shaft.
- (viii): Check that the rudder lock placard on the handle cover plate is legible and secure. Install a new placard if needed:
 - P/N 5100181-20: English Placard, Black Letters / Transparent Field
 - P/N 5100181-21: English Placard, White Letters / Transparent Field
 - P/N AT-RL-SP01: Spanish Placard, Black Letters / Transparent Field
 - P/N AT-RL-SP02: Spanish Placard, White Letters / Transparent Field
 - P/N AT3001-P-BL1: English and Portuguese, Black Letters / Transparent Field
 - P/N AT3001-P-BL2: English and Portuguese, White Letters / Transparent Field

1.7 General Operational Check

- (i): Check operation by first securing the elevator with the control yoke lock, then engaging the rudder lock.
- (ii): With the rudder lock engaged, the rudder should only move about ½ inch at its trailing edge.
- (iii): Remove the elevator control yoke lock and pull back on the yoke. The rudder lock should disengage.
- (iv): With the lock free, the rudder should move freely with at least 1/8 inch minimum clearance between the top of the rudder lock body and the bottom of the strike plate on the rudder.

1.8 Weight and Balance

The weight, arm, and moment of the installed rudder gust lock assembly is as follows:

	<u>Wt.(lb.)</u>	<u>F.S. (in)</u>	<u>Mom/1000</u>
Model 208 &208A:	4.0	437.6	1.75
Model 208B:	4.0	485.6	1.94

2.0 Airworthiness Limitations

Aero Twin, Inc. Rudder Gust Lock Kit No. AT-RL-1001

The Airworthiness Limitations section is FAA approved and specifies maintenance required under paragraphs 43.16 and 91.403(c) of the Federal Aviation Regulations unless an alternative program has been FAA approved.

This section describes required inspections and maintenance. There are no scheduled replacement items. When repairs are deemed necessary, follow accepted standard practices and/or specific maintenance instructions in Section 1 of this manual.

This section constitutes Component Airworthiness Limitations which apply to the rudder gust lock installation only.

2.1 Scheduled Inspections and Maintenance:

The rudder gust lock assembly must be inspected every 200 flight hours. **When operated in a salt-water environment, the rudder gust lock assembly must be inspected every 100 flight hours or 3 months, which ever occurs first.**

To inspect the mechanism:

1. Perform a Condition Inspection in accordance with paragraph 1.6 of this document.
2. Perform a General Operational Check in accordance with paragraph 1.7 of this document.

FAA Approval: _____

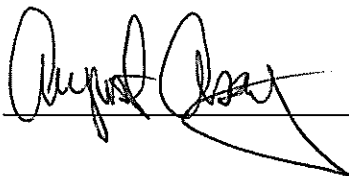

-----End of Section 2.0 Airworthiness Limitations-----

3.0 Illustrated Parts List

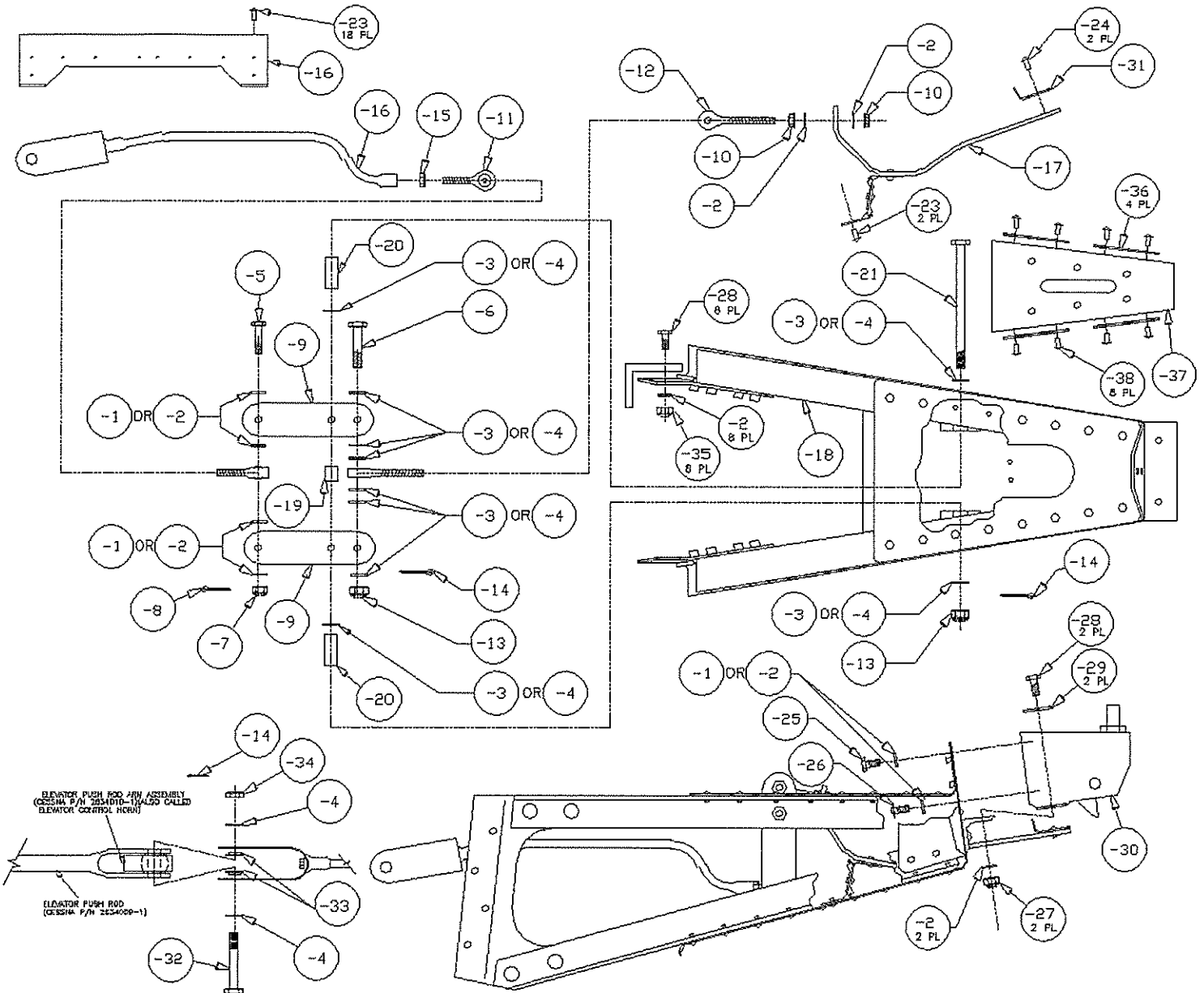

-1	--	NAS1149F0363P	WASHER	QUANTITY MAY VARY.
-2	--	NAS1149F0332P	WASHER	QUANTITY MAY VARY.
-3	--	NAS1149F0463P	WASHER	QUANTITY MAY VARY.
-4	--	NAS1149F0432P	WASHER	QUANTITY MAY VARY.
-5	1	AN3-7	BOLT	
-6	1	AN4-10	BOLT	
-7	1	AN310-3	CASTLE NUT	
-8	1	MS24665-132	COTTER PIN	
-9	2	AT-RL-1003	BELL CRANK	
-10	2	MS21042-L3	LOCK NUT	
-11	1	S1105-3	TIE ROD END	
-12	1	AT-RL-1009	PIN EYE	
-13	2	AN310-4	CASTLE NUT	
-14	3	MS24665-134	COTTER PIN	
-15	1	AN315-3R	LOCK NUT	
-16	1	AT-RL-1020	CONNECTION TUBE ASSEMBLY	
-17	1	AT-RL-1002	RELEASE ROD ASSEMBLY W/ HINGE P/N AT-RL-1005	
-18	1	AT-RL-1010	MOUNTING BRACKET	
-19	1	AT-RL-1008	INNER BUSHING	
ITEM	QTY	PART NO.	DESCRIPTION	

-20	2	AT-RL-1006	OUTER BUSHING	
-21	1	AN4-35	BOLT	
-23	20	MS20470AD4-4	RIVETS	
-24	2	MS20470AD4-6	RIVETS	
-25	1	AN3-3A	BOLT	
-26	1	AN525-10R7	SCREW	ALT: AN525-10R6
-27	2	MS21045-3	LOCK NUT	
-28	10	AN3-5A	BOLT	
-29	2	AN970-3	WASHER	
-30	1	4111-1	RUDDER LOCK ASSEMBLY	
-31	1	AT-RL-1007	RELEASE ROD STOP	
-32	1	AN4-14	BOLT	
-33	1	NAS77-4-006	BUSHING, FLANGED	
-34	1	MS17825-4	CASTLE NUT	
-35	8	MS21044N3	NUT	
-36	4	AT-RL-1018	SHIM	
-37	1	AT-RL-1027	RUDDER STRIKE PLATE	-1030 FOR FLOATPLANE
-38	8	CR3243-4-3	RIVET	
-39	1	AT-RL-1024	DOUBLER	
ITEM	QTY	PART NO.	DESCRIPTION	