

# **INSTRUCTIONS FOR CONTINUED AIRWORTHINESS**

**Aero Twin, Inc. Main Gear Gravel Deflector Kit No. GDQ-100**  
for  
**Quest Model 100 Aircraft**

Document No. GDQ-100-ICA

Maintenance Manual  
Airworthiness Limitations  
Illustrated Parts List

<b>LOG OF REVISIONS</b>			
REVISIONS		PAGES REVISED AND DESCRIPTION OF REVISIONS	APPROVAL SIGNATURE
NO.	DATE		
N/C	2/14/09	Original Issue	<i>Jason Hyhn</i>

Information in this publication is based on data available at the time of publication and may be updated, supplemented, and automatically amended by a revision or re-issuance. All such amendments become part of and are specifically incorporated within this publication. Users are urged to keep abreast of the latest amendments to this publication through information available on Aero Twin, Inc.'s website, <http://www.aerotwin.com>. The latest revision of the Instructions for Continued Airworthiness for all of Aero Twin, Inc.'s products are available for download at that website.

## Table of Contents

<b>Section</b>	<b>Page</b>
<b>Log of Revisions.....</b>	<b>2</b>
<b>Table of Contents .....</b>	<b>3</b>
<b>1.0 Maintenance Manual .....</b>	<b>4</b>
<b>1.1 Description.....</b>	<b>4</b>
<b>1.2 Installation/Removal.....</b>	<b>4</b>
<b>1.3 Weight and Balance.....</b>	<b>5</b>
<b>1.4 Maintenance Instructions .....</b>	<b>5</b>
<b>2.0 Airworthiness Limitations.....</b>	<b>7</b>
<b>3.0 Illustrated Parts List .....</b>	<b>8</b>
<b>3.1 Complete Parts List .....</b>	<b>8</b>
<b>Drawing GD28-A, Sheet 3 of 3 .....</b>	<b>8</b>
<b>Drawing GDQ-I, Sheet 1 of 2 .....</b>	<b>9</b>
<b>Drawing GDQ-I, Sheet 2 of 2 .....</b>	<b>10</b>

# 1.0 Maintenance Manual

## Aero Twin, Inc. Main Gear Gravel Deflector, Kit No. NGDQ-100

### 1.1 Description

The Aero Twin main gear gravel deflectors for the Quest Kodiak aircraft consists of steel frames that are bolted to the landing gear using the top two axle bolts. The steel frames extend aft around the rear of each main tire, where they support rubber mud flaps and tire scrapers. The gravel deflectors provide protection from rock damage to the aircraft.

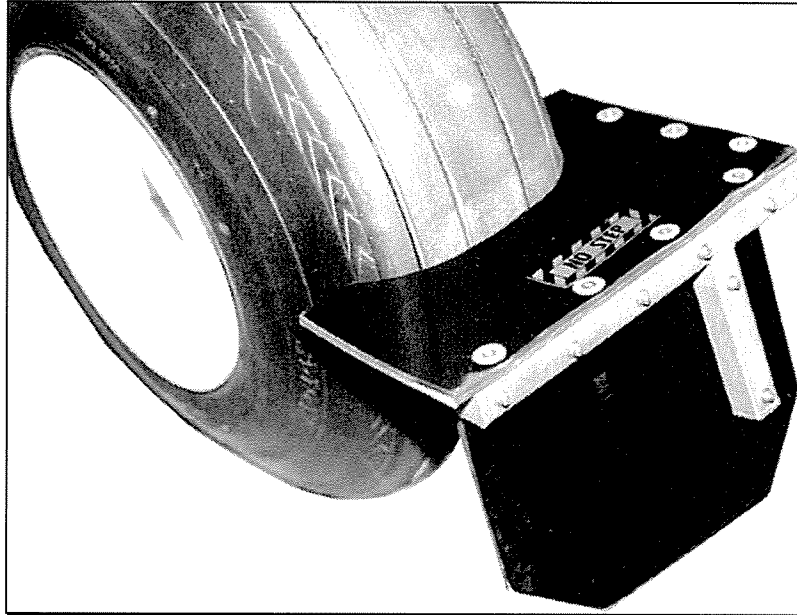

Figure 1.1.1 Main Gear Gravel Deflector

### 1.2 Installation / Removal

(Refer to drawing GDQ-I, 2 sheets)

#### 1.2.1 Installation:

1. Remove left main wheel assembly per FAA approved maintenance manual.
2. Remove nuts and washers from upper two axle bolts, and remove bolts.
3. Install the left gravel deflector as using the supplied hardware shown on drawing GDQ-I, sheet 1: Use NAS1149F0963P and/or NAS1149F0932P washers as required for correct thread exposure.
4. Install new nuts and torque per FAA approved maintenance manual. Reinstall wheel assembly.
5. Install right gravel deflector following the same procedure (steps 1-4).
6. Fit the rubber tire scrapers on the top surface of the installed gravel deflector frames, with the circular cut-out butted against the tire's tread. Using a 3/16 drill bit, match-drill the fastener holes upward through the frame and then through the fitted rubber scraper. Bore out the holes in the rubber scraper using a 1/4 drill bit.
7. Install the tire scrapers using the supplied hardware as shown in drawing GDQ-I, sheet 2.

8. Trim excess material from edge of scrapers, flush with outer edge of frame.
9. Affix "NO STEP" placard to top surface of scraper, centered at rear edge.
10. Execute FAA form 337 in duplicate, stating that this gravel deflector kit was installed in accordance with this STC. The total change in airplane empty weight and balance is 13.0 lb. at fuselage station 105.6.

#### **1.2.2 Removal:**

1. To remove the gravel deflectors, remove the main wheel assembly per FAA approved maintenance manual.
2. Remove two bolts attaching the gravel deflectors to the aircraft and replace them with standard length bolts listed in Quest's illustrated parts catalog, installing new nuts and washers on the bolts.
3. Reinstall the main wheel assembly per FAA approved maintenance manual.
4. Update the weight and balance as specified in section 1.3.

### **1.3 Weight and Balance**

---

When the gravel deflectors are installed or removed, the aircraft empty weight and balance must be updated to reflect the configuration change. This section includes information required for weight and balance calculations pertaining to the installation of the nose gear gravel deflector.

The total weight of the gravel deflectors is 13.0 pounds and their center of gravity is located at fuselage station 105.6, giving a total moment of 1372.8 in-lbs. When the deflectors are installed on the aircraft, the weight of the deflectors must be added to the empty aircraft weight. The moment contribution from the gravel deflector must be added to the previous empty aircraft moment. The new empty aircraft center of gravity is then calculated by dividing the new moment by the new empty weight. If the gravel deflectors are removed from the aircraft, the weight and balance of the aircraft must be updated by subtracting the weight and moment contribution of the gravel deflectors from the empty aircraft weight and moment and dividing the new moment by the new weight to achieve the new aircraft center of gravity.

### **1.4 Maintenance Instructions**

---

#### **1.4.1 General:**

The Aero Twin Main Gear Gravel Deflector installation is designed to be highly durable and fairly maintenance free. However, a maintenance program has been established, in accordance with Appendix G of 14 CFR Part 23, to assure the continued airworthiness of the gravel deflector and its installation. Adherence to the established plan is mandatory and records of performance of required inspections and maintenance must be maintained. See Section 2.0, Airworthiness Limitations, for required maintenance items and intervals.

#### **1.4.2 Corrosion Prevention:**

The steel frames of the gravel deflectors are powder coated to protect the structure from the elements. The finish on the gravel deflector parts must be inspected to ensure adequate corrosion prevention. If the powder coated surface of the steel tube structures are marred in service or during handling, the affected area should be stripped and repainted to prevent corrosion, see paragraph 1.4.4.3. Corrosion prevention is also enhanced by keeping the structure clean. The

steel and rubber parts of the gravel deflector should be kept free of dirt and may be cleaned using water and a mild detergent.

### **1.4.3 Disassembly / Assembly:** (Refer to drawings GD28-A, sheet 3 of 3, and GDQ-I, 2 sheets)

#### 1.4.3.1 Disassembly:

- The rubber mud flap and tire scraper on the gravel deflectors should be inspected for wear and may need to be replaced periodically when they are ineffective in protecting the aircraft from rock damage. To remove the mud flap, remove the seven MS24694S68 screws from the back of the frame along with the MS21042L3 nuts, A3235-028-935 countersunk washers, and NAS1149F0332P washers used with those screws. To remove the tire scraper, remove the five MS24694S68 screws and two MS24694S70 screws from the top of the frame along with the nuts, countersunk washers, and washers.

#### 1.4.3.2 Assembly:

- A new mud flap will require the attachment screw holes to be match drilled using a #10 drill bit. After match drilling the holes in the rubber, bore out the holes in the rubber using a ¼ inch drill bit. To install the mud flap, attach it to the frame using seven MS24694S68 screws, A3235-028-935 countersunk washers, NAS1149F0332P washers, and MS21042L3 locknuts. (Use new locknuts.)
- To install a new tire scraper, place the scraper on the top surface of the frame, snug against the tire and drill seven 3/16 holes through the scraper to match the seven fastener locations on top of the frame. Bore out the matchdrilled holes in the rubber using a ¼ inch drill bit. Install the scraper on top of the frame using five MS24694S68 screws, two MS24694S70 screws, and seven each A3235-028-935 countersunk washers, NAS1149F0332P washers, and MS21042LS locknuts. (Use new locknuts.)
- Use standard torques specified in the FAA approved Quest Maintenance Manual.

### **1.4.4 Gravel Deflector Repair:**

#### 1.4.4.1 Hardware Replacement:

Hardware and fittings used throughout the gravel deflectors are aircraft standard. Hardware should be replaced if corroded, damaged, or excessively worn. Replace self-locking type nuts with new hardware when reassembling or reinstalling the gravel deflectors. Do not substitute hardware - refer to the Illustrated Parts List for correct part numbers. If you encounter difficulty procuring replacement hardware or fittings, contact Aero Twin, Inc. at (907) 274-6166. Refer to previous section for assembly information.

#### 1.4.4.2 Steel Tube Frame:

**Before any repairs may be made to the steel tube frame, written approval must be obtained from the manufacturer, Aero Twin Inc. Contact Aero Twin Engineering Department at (907) 274-6166 or write: Aero Twin Inc., Engineering Dept., 2403 Merrill Field Dr., Anchorage AK, 99501.**

#### 1.4.4.3 Painted and Powder Coated Surfaces:

Painted and powder coated surfaces should be maintained and refinished as required to prevent corrosion. When refinishing of a painted surface is required, lightly sand the affected area using fine sandpaper or an abrasive pad (such as 3M *Scotch-Brite*™). When refinishing a powder coated surface, a commercial grade stripper may be used. Polish out

minor surface nicks or scratches where present. Clean the area thoroughly with a clean cloth wetted with non-petroleum-based solvent to remove any residual oils and dust. Apply a zinc-chromate or equivalent primer coat, then a matching color coat of quality enamel or epoxy-type paint. Follow manufacturer's instructions in preparing and applying primer and color coats. If a surface was previously powder coated, and it is desired to keep a powder coat finish, contact Aero Twin, Inc. at (907)274-6166.

## 2.0 Airworthiness Limitations

### Aero Twin, Inc. Main Gear Gravel Deflector Kit No. GDQ-100

**The Airworthiness Limitations section is FAA approved and specifies maintenance required under paragraphs 43.16 and 91.403 of the Federal Aviation Regulations unless an alternative program has been FAA approved.**

This section describes required inspection, maintenance, and replacement items. When repairs are deemed necessary, follow accepted standard practices and/or specific maintenance instructions in Section 1.4 of this manual. This section constitutes Component Airworthiness Limitations which apply to the main gear gravel deflector installation only.

#### 2.1 Scheduled Inspections and Maintenance:

Note: First inspection should be accomplished at next aircraft inspection requiring inspection of the main wheel assembly so that subsequent inspections coincide.

At each inspection interval for which inspection of the main wheel assembly is required by the FAA approved Quest 100 Maintenance Manual or other FAA approved maintenance program for the aircraft, the following inspections shall be performed on the main gear gravel deflector:

- Visually inspect the steel structure for cracks, bends, dents, corrosion, or other defects.
- Visually inspect the mud flap and tire scraper for security and condition.
- Visually inspect the hardware and fittings for security and condition.

At intervals not to exceed 500 hours or Annual Inspection, remove the gravel deflector from the main landing gear assembly and perform the following inspections:

- Visually inspect the steel structure for cracks, bends, dents, corrosion, or other defects.
- Visually inspect the mud flap and tire scraper for security and condition.
- Visually inspect the hardware and fittings for security and condition.
- Replace all self locking nuts used to attach the gravel deflectors to the main landing gear.

FAA Approved: \_\_\_\_\_



-----End of Section 2.0 Airworthiness Limitations-----

# 3.0 Illustrated Parts List

## Aero Twin, Inc. Main Gear Gravel Deflectors, Kit No. GDQ-100

### 3.1 Complete Parts List:

Drawings GD28-A, sheet 3 of 3, and GDQ-I, two sheets, are provided here for a listing of all gravel deflector parts and hardware. Deflector, P/N GD8-113, is installed prior to delivery. Drawing DG28-A, sheet 3 of 3, is provided only for reference in replacing the deflector.

**GRAVEL DEFLECTOR ASSEMBLY P/N 208GD-L(R)**  
(LEFT SHOWN; RIGHT OPPOSITE)

**NOTE:**  
 ▲ REMOVE BURRS AND SHARP EDGES FROM WELDED FRAME.  
 ▲ STAMP SERIAL NUMBER AT LOCATION SHOWN; NUMBER TO BE DETERMINED AT TIME OF MANUFACTURE;  
 ▲ SAMPLE NUMBER SHOWN.  
 ▲ MATCH DRILL (#10) HOLES THRU RUBBER DEFLECTOR (7 PL.); BORE-OUT HOLES (IN DEFLECTOR)  
 ▲ USING 0.25 BIT.  
 ▲ TORQUE NUTS TO 10-15 IN/LBS.

ITEM	QTY	PART NO.	DESCRIPTION	MATERIAL	DIMENSION	SPECIFICATION
-1	2	GD8-113	DEFLECTOR			GD2-PR.1 OF 3
-2	1(L/R)	GD8-115-L(R)	GRAVEL DEFLECTOR WELDMENT			
-3	14	MS7162-13	NUT			
-4	14	MS20426-03	WASHER			
-5	14	MS20426-03	WASHER			
-6	14	MS24694-268	SCREW			

A. ISSUED PER ECO AT-13402-14-08 JMK  
 ORIGINAL PER ECO AT-3707-04-97 DRG  
 LET REVISION DATE INIT

**AERO TWIN, INC.**  
 2403 HERRILL FIELD DRIVE ANCHORAGE AK 99501  
 CESSNA 208 AND QUEST 100

**RUBBER DEFLECTOR  
 INSTALLATION**

X.Y. = ± 0.1 X.Z. = ± 0.05 X.V. = ± 0.1 X.W. = ± 0.1  
 DWR: DRG DATE: 08-27-97 SCALE: NTS  
 APP'D: M. LOVELL DWG: GD28-A  
 SHEET: 3 OF 3

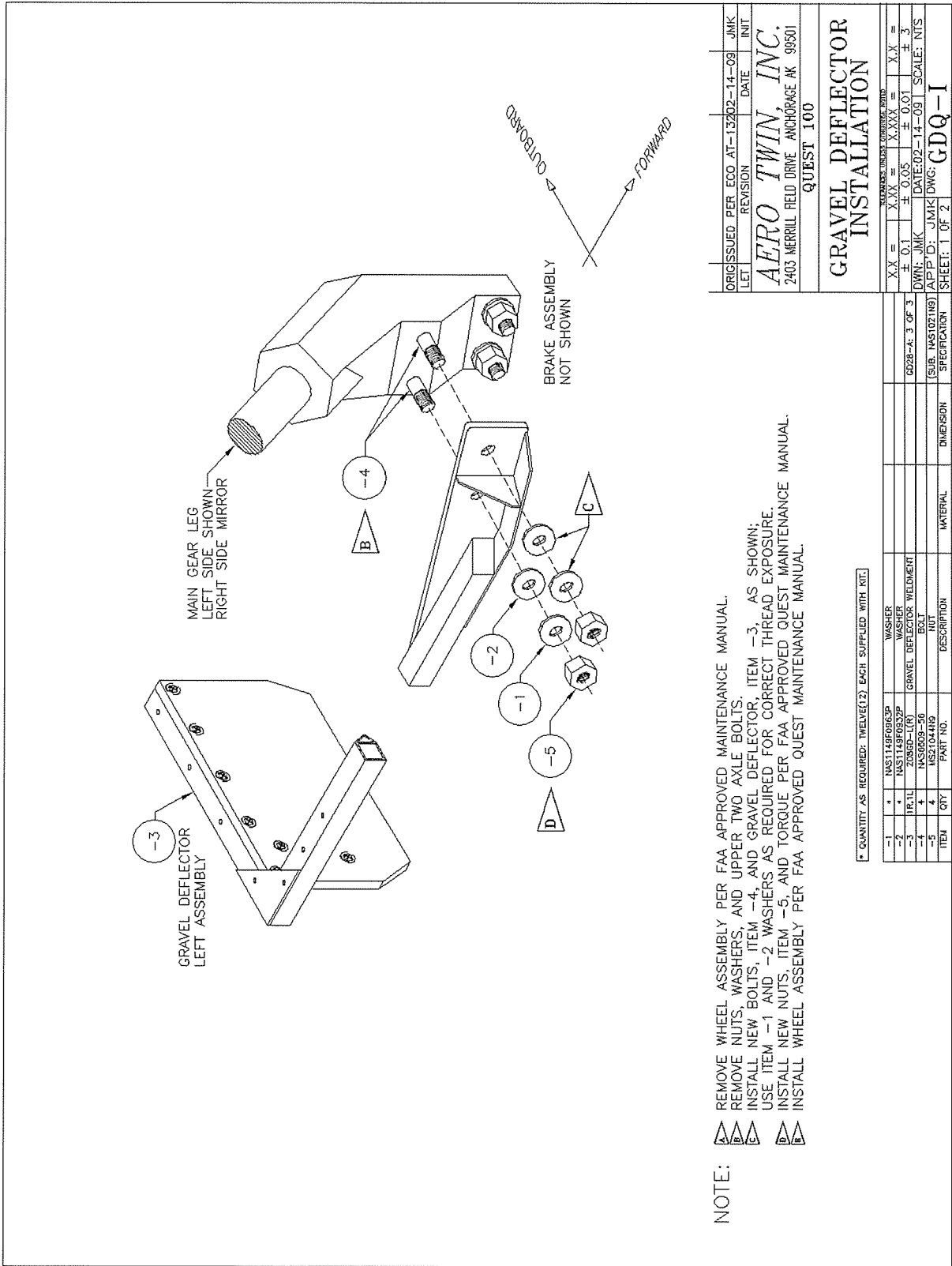

ISSUED PER EOO AT-13202-14-09	JMK
REVISION	DATE
INIT	
<b>AERO TWIN, INC.</b>	
2403 MERRILL FIELD DRIVE ANCHORAGE AK 99501	
QUEST 100	
<b>GRAVEL DEFLECTOR INSTALLATION</b>	
XX =	XXXX =
± 0.1	± 0.05
DWG: JMK	DATE: 02-14-09
JAP/D: JMK	SCALE: NTS
SHEET: 1 OF 2	

\* QUANTITY AS REQUIRED; TWELVE(12) EACH SUPPLIED WITH KIT.

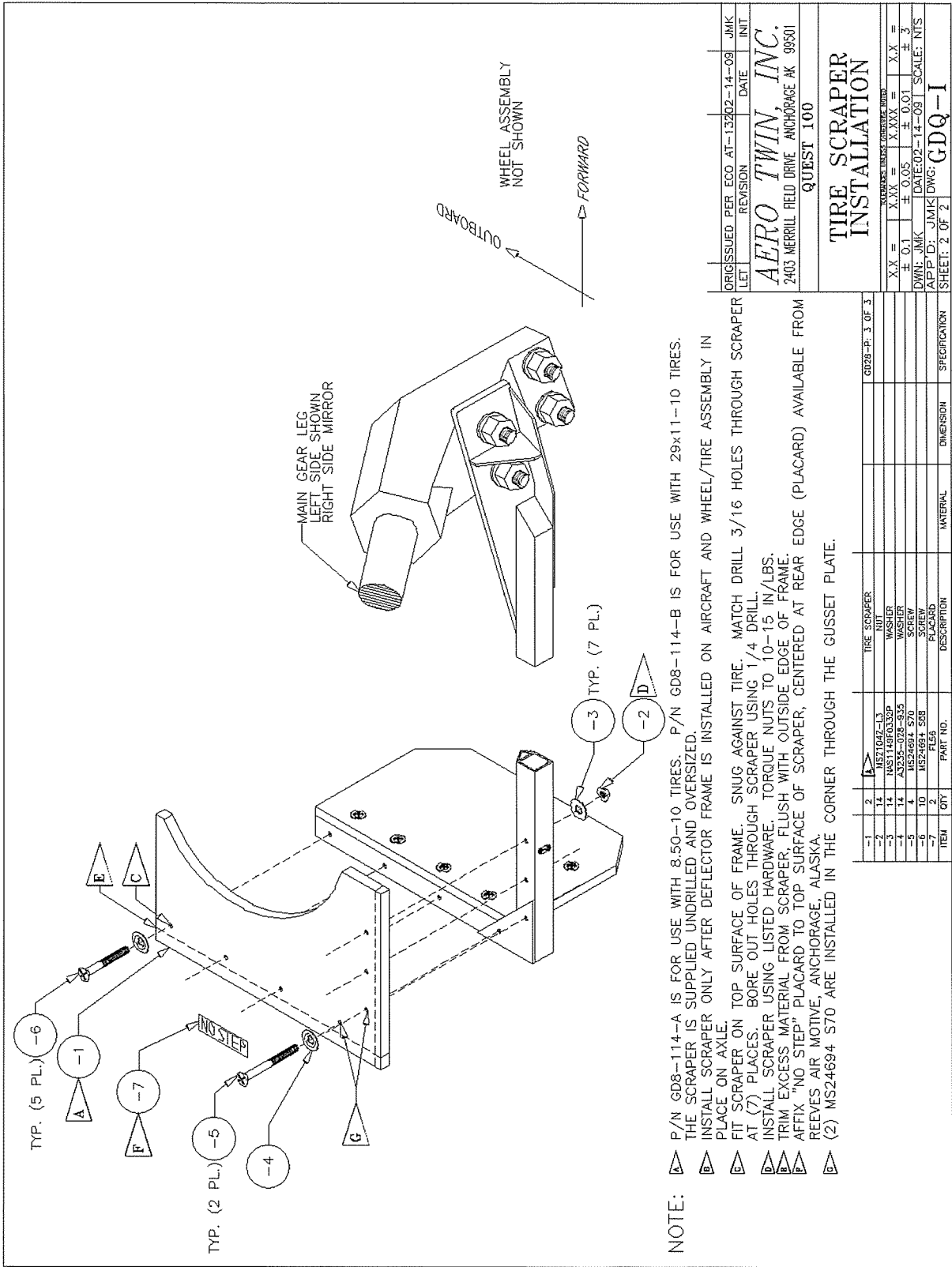

**NOTE:**

- ▲ P/N GD8-114-A IS FOR USE WITH 8.50-10 TIRES. P/N GD8-114-B IS FOR USE WITH 29x11-10 TIRES.
- ▲ THE SCRAPER IS SUPPLIED UNDRILLED AND OVERSIZED.
- ▲ INSTALL SCRAPER ONLY AFTER DEFLECTOR FRAME IS INSTALLED ON AIRCRAFT AND WHEEL/TIRE ASSEMBLY IN PLACE ON AXLE.
- ▲ FIT SCRAPER ON TOP SURFACE OF FRAME. SNUG AGAINST TIRE. MATCH DRILL 3/16 HOLES THROUGH SCRAPER AT (7) PLACES. BORE OUT HOLES THROUGH SCRAPER USING 1/4 DRILL.
- ▲ INSTALL SCRAPER USING LISTED HARDWARE. TORQUE NUTS TO 10-15 IN./LBS.
- ▲ TRIM EXCESS MATERIAL FROM SCRAPER. FLUSH WITH OUTSIDE EDGE OF FRAME.
- ▲ AFFIX "NO STEP" PLACARD TO TOP SURFACE OF SCRAPER, CENTERED AT REAR EDGE (PLACARD) AVAILABLE FROM REEVES AIR MOTIVE, ANCHORAGE, ALASKA.
- ▲ (2) MS24694 S70 ARE INSTALLED IN THE CORNER THROUGH THE GUSSET PLATE.

ORIGINATED PER ECO AT-13202-14-09	JMK
LET	INIT
REVISION	DATE
<b>AERO TWIN, INC.</b>	
2403 MERRILL FIELD DRIVE, ANCHORAGE AK 99501	
QUEST 100	
<b>TIRE SCRAPER INSTALLATION</b>	
TOLERANCES UNLESS OTHERWISE NOTED	
X.X =	X.XXX =
± 0.1	± 0.05
DWN: JMK	DATE: 02-14-09
APP'D: JMK	SCALE: NTS
SHEET: 2 OF 2	

ITEM	QTY	PART NO.	DESCRIPTION	MATERIAL	DIMENSION	SPECIFICATION
1	1	▲	TIRE SCRAPER			GD28-P. 3 OF 3
2	14	MS27104Z-L5	NUT			
3	14	MS24694 S70	WASHER			
4	4	MS24694 S70	SCREW			
5	10	MS24694 S70	SCREW			
6	2	FL56	PLACARD			