

**INSTRUCTIONS FOR CONTINUED
AIRWORTHINESS AND INSTALLATION
INSTRUCTIONS**

Aero Twin, Inc. Single Place Folding Seat Kit No. DFS-KOD
for
Quest Model 100 Kodiak

Document No. DFS-KOD-ICA

Component Maintenance Manual
Airworthiness Limitations
Illustrated Parts List

Original Issue

Date: December 25, 2008

Table of Contents

Section	Page
Log of Revisions	2
Table of Contents	3
1.0 Maintenance Manual.....	4
1.1 Description	4
1.2 Installation/Removal	5
1.3 Storage	7
1.4 Weight and Balance.....	8
1.5 Maintenance Instructions	9
2.0 Airworthiness Limitations	13
2.1 Scheduled Inspections and Maintenance.....	13
2.2 Mandatory Replacement.....	14
3.0 Illustrated Parts List.....	15
3.1 Complete Parts List.....	15
3.2 Folding Seat Overview & Back Rest Cover Installation	16
3.3 Seat Bottom Hardware & Lower Arm Installation	17
3.4 Seat Belt and Back Installation	18
3.5 Lower Arm Detail.....	19
3.6 Seat Pan Installation.....	20
3.7 Seat Cushion Assembly and Data Plate Installation.....	21

1.0 Maintenance Manual

Aero Twin, Inc. Single Place Folding Seat, P/N DFS2T

1.1 Description

The Aero Twin single place folding seat is designed for quick and simple installation or removal, and compact stowage when not in use. The seat is to be installed in Quest Model 100 aircraft. The basic structure of the seat is a welded 4130 steel tube frame. The seat back and legs fold for storage. Two lower diagonal arms, each hinged at one end and equipped with a quick-release fitting at the other, provide primary structural support for the installed seat. Upper arms equipped with quick release fittings support the seat back. The seat pan is rubber-impregnated high-strength fabric attached to the seat frame with aluminum inserts and steel screws. The seat back cover is of the same material; it slides over the seat back frame and is secured with nylon straps. Lap and shoulder belts attached to the pan frames and seat back, respectively, provide occupant restraint. The left side seats have the shoulder harness attached on the left hand side of the seat back and the right side versions have them on the right hand side. The seat is equipped with four identical anti-rattle type track fittings that engage the seat tracks. A two-piece padded upholstery cover is supplied with each seat; this slides over the seat pan frame and back and is secured with Velcro® strips. The seat is identified by a data plate permanently attached to the inside of the right rear leg. The data plate lists the name and address of the manufacturer; the name, type, and part number of the seat; the serial number of the seat; and the TSO number (C127a) for the seat. Additionally, the seat back cushion is identified by an auxiliary data plate attached to the lower left corner of the back side of the cushion cover. Similarly, an auxiliary data plate is attached to the left side of the rear face of the bottom seat cover. These auxiliary data plates list the manufacturer's name, the seat cushion part number and the TSO number (C-127a).

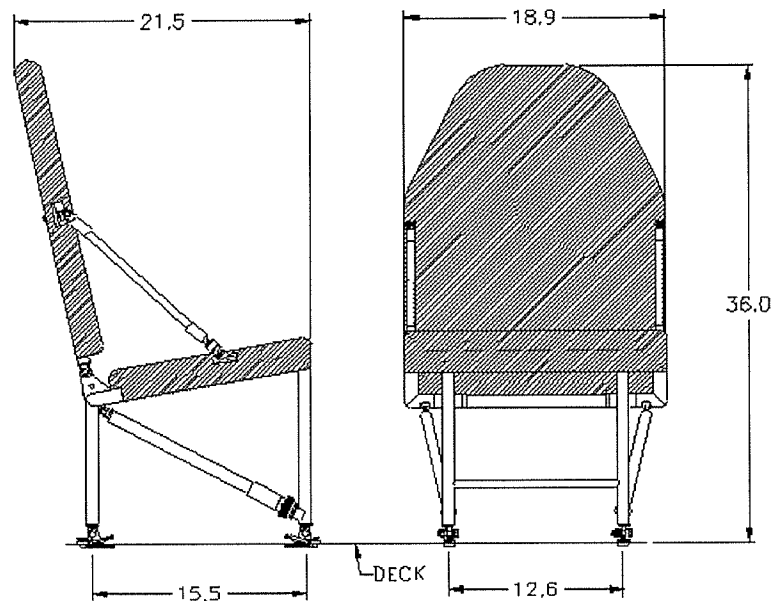

Figure 1.1.1 Basic Seat Dimensions

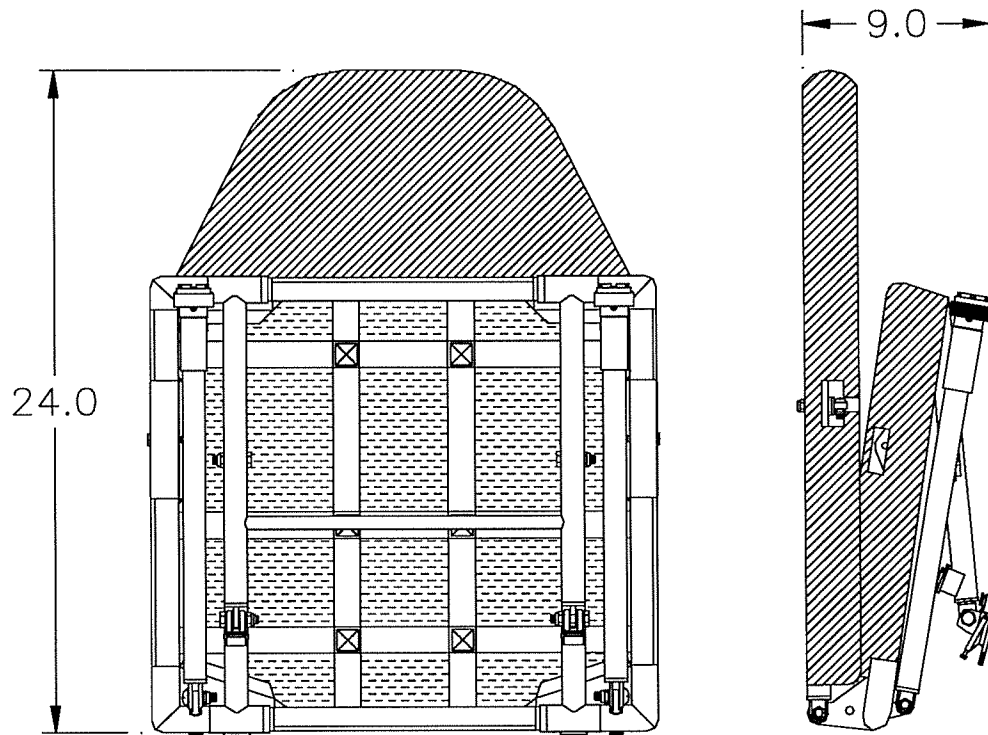

Figure 1.1.2 Folded Seat Dimensions

1.2 Installation / Removal

NOTE: This seat is certified for forward-facing installation only.

This section describes general installation procedures; for information on allowable interior configurations, and corresponding weight and balance data see Section 1.4.

NOTE: Seats with the shoulder harness attached on the left side of the seat back may be installed on the left side of the airplane only. Seats with the shoulder harness attached on the right side of the seat back may be installed on the right side of the airplane only. The following part numbers apply:

Left Seat P/N: DFS2T-L
Right Seat P/N: DFS2T-R

1.2.1 Setup and Installation (see Figure 1.2.1):

1. Unfold forward legs and lower diagonal arms. On each lower arm quick-release fitting, push in the retaining pin and retract the locking ring (detail 1, Figure 1.2.1). Position the arms to align fittings with studs on forward legs. Push forward leg back to engage studs in fittings, then extend locking rings to close jaws.

Be sure jaws close completely and retaining pins pop out to the extended (locked) position - Failure to properly engage studs and lock fittings could result in seat collapse.

2. Unfold seat back and upper diagonal arms. Position the arms so the quick-release fittings are over the corresponding pins on the seat frame. Retract the spring-loaded collar on one fitting, push the fitting over the pin, then release the collar. Repeat for the opposite side (detail 3, Figure 1.2.1).

Be sure the collars extend completely and the pins are properly captured in the fittings - failure to properly engage pins could result in seat collapse.

3. Unfold rear legs and position the seat over the seat tracks at the desired fuselage station. Drop the forward feet into the tracks (locking lugs must be in the retracted position), slide forward or aft 1/2 inch, and push the locking lugs down to lock the forward feet into the track (detail 2, Figure 1.2.1).
4. The rear leg locking lugs should be 17 inches (17 track positions) aft of the forward feet locking lugs, when properly positioned in the seat track.
5. The feet are equipped with anti-rattle devices. Use is optional. To use the anti-rattle feature, tighten the screw in the anti-rattle device until the stirrup is drawn snug against the seat track.
6. Update aircraft empty weight and balance to account for seat installation (see Section 1.4).

1.2.2 Removal / Breakdown:

1. Release anti-rattle feature on each of four feet (if feature is utilized).
2. Lift the rear feet locking lugs (a tool, P/N AT-SRT-01, designed for this purpose is available from Aero Twin, Inc.). Slide the feet forward 1/2 inch and lift the feet from the track.
3. Repeat step 3 for the forward feet. Remove seat from tracks.
4. Push in the retaining pins and retract the locking rings of the lower diagonal arm quick-release fittings. Disengage the forward leg studs from the fittings.
5. **Fold the rear legs in first, then the forward legs.** Fold the lower arms into position alongside the forward legs.
6. Retract the spring-loaded collar on the quick release fitting on one of the upper diagonal arms and disengage the fitting from the pin on the seat frame. Repeat for the other arm.
7. Rotate and fold the upper arms inward across the seat back - note that the eyebolts in the seat back, to which the arms are attached, rotate in their bushings to accomplish this. The seat will fold best when the arms are positioned so that they do not cross each other.
8. Fold the back rest and seat base together.

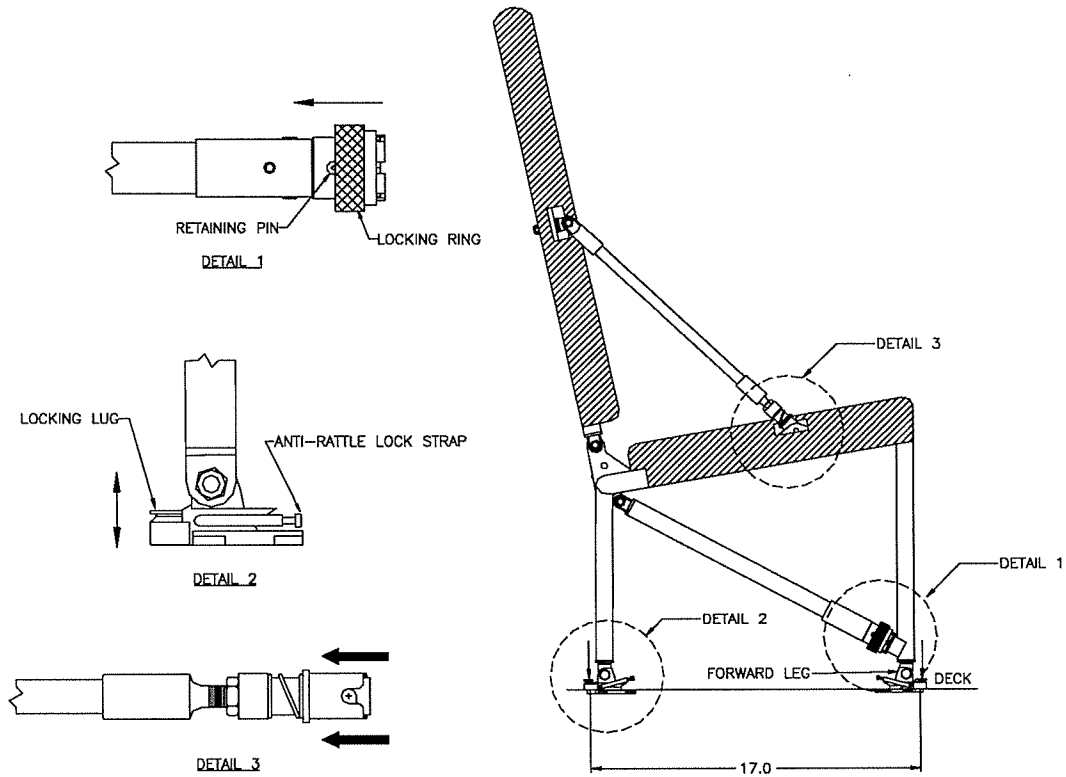

Figure 1.2.1 Seat Installation

1.3 Storage

During storage the seats should be kept in a dry location away from any direct heat source. The seats can be stacked up to six-deep in storage. Do not stack more than 100 lb. on top of a folded seat. Prior to installing a seat which has been in storage for an extended period, inspect and lubricate the seat in accordance with a 1000 hr/Annual inspection, as described in section 2.1.1.

1.4 Weight and Balance

The Aero Twin, Inc. P/N DFS2T seats are meant to be direct replacements for the standard seats installed in the aircraft by Quest. These seats may be installed in the same locations allowed by Quest for the standard seats, including any of the configurations allowed in the Quest Pilot's Operating Handbook and Aircraft Flight Manual. Figure 1.4.1 shows the fuselage stations of the installed seats in the standard seating configuration with eight aft passenger seats. When installing the DFS2T seats, the aircraft empty weight and balance must be updated using table 1.4.1. Beginning with the weight and moment of the empty aircraft without the seats, add the weight and moment contribution of each installed seat to determine the empty aircraft weight and moment with the seats installed. **The weight of one DFS2T seat is 27 pounds.** This includes all cushions and upholstery, which must be installed on the seat at all times when the aircraft is in operation. Note that the individual seat center of gravity location is 7.5 inches forward of the aft feet locking lugs. (See Figure 1.4.2.)

	Weight	Moment/ 1000
Basic Empty Aircraft Without Seats		
Row 1, Left (FS 77.5)		
Row 1, Right (FS 77.5)		
Row 2, Left (FS 108.5)		
Row 2, Right (FS 108.5)		
Row 3, Left (FS 139.5)		
Row 3, Right (FS 139.5)		
Row 4, Left (FS 170.5)		
Row 4, Right (FS 170.5)		
Empty Aircraft With Seats (Sum Each Column)		

Note: Seat spacing may not be less than 31 inches. The backrest of a seat may not be less than 31 inches from any object in front of it (see Fig. 1.4.1).

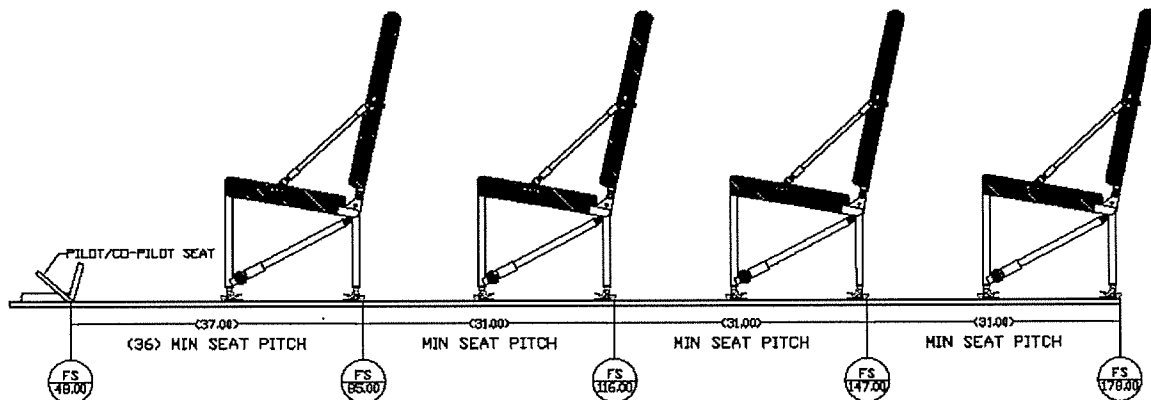

Figure 1.4.1 Approved Seat Locations and Spacing Requirements

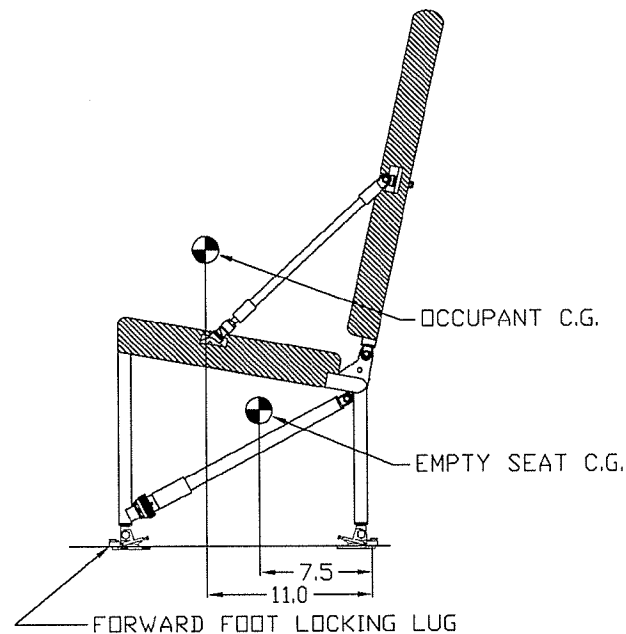

Figure 1.4.2
Seat Center of Gravity

1.5 Maintenance Instructions

1.5.1 General:

The Aero Twin Single Place Folding Seat is designed to be highly durable and fairly maintenance free. However, a maintenance program has been established, in accordance with Appendix G of 14 CFR Part 23, to assure the continued airworthiness of the seats. Adherence to the established plan is mandatory and records of performance of required inspections and maintenance must be maintained. See Section 2.0, Airworthiness Limitations, for required maintenance items and intervals.

1.5.2 Cleaning:

1.5.2.1 Upholstery:

- For general dust and light dry soiling, vacuum upholstery thoroughly, and or brush with a clean stiff bristle brush. Avoid beating fabric as this can hasten wear and does not effectively clean the upholstery. Use of commercially available upholstery shampoo will remove most soil encountered in normal service. Follow product directions.
- For oil or grease stains, solvent-type cleaning agents can be effective. Test a small inconspicuous area of the fabric first. Use solvent-type agents sparingly, without saturating fabric. Apply with a clean soft cloth and work from the edge of the stain towards the center to avoid spreading. Observe appropriate safety precautions when using any solvent agent.
- For heavy, saturating stains (coffee, vomit, etc.) the upholstery cover should be removed and commercially dry-cleaned.

1.5.2.2 Seat Track:

The track should be kept clean, as dirt and contaminants can wear on the track and cause difficulty in installing and removing hardware. Cleaning may be done in a variety of ways as long as chemicals or tools used do not corrode or wear down the track.

1.5.2.3 Herculite fabric (seat pan and seat back cover):

Clean the Herculite fabric components using mild soap and water solution or a commercial vinyl cleaner. For heavy grease or oil stains, a diluted solution of Simple Green or equivalent cleaning solution can be used. Avoid excessive wetting of the fabric when installed on the seat, as moisture can collect between the fabric and tube structure and promote corrosion.

1.5.2.4 Metal Parts:

Moisten a clean soft cloth with a solvent-type cleaner or undiluted Simple Green or equivalent; thoroughly wipe metal parts completely clean. Wipe dry with a clean dry cloth. After heavy cleaning over or near lubricated joints, relubricate as appropriate.

1.5.3 Lubrication and Corrosion Prevention:

The hinged leg connections to the seat frame are areas that must be kept well lubricated and protected from moisture. *Corrosion X*TM is a product that is well suited to this dual purpose. This product is available from Aero Twin, Inc., or your local aviation supplier. Other commercial products are available that will perform well. WD-40 is not recommended, as its moisture displacement properties are inadequate.

The required maintenance procedures for the seat include lubrication and internal treatment of the steel tubes at specific intervals. The seat should also be lubricated if it is subjected to heavy moisture for any reason, or after thorough cleaning of the metal frame.

- To lubricate the rotating and sliding joints, spray lubricant into the joint while rotating or sliding the fitting (avoid over spray on the upholstery cover by first pulling the cover back from the joint). Wipe off all excess lubricant with a clean dry cloth.
- To internally treat the steel tubes, the upholstery cover and Herculite fabric seat pan and seat back cover should be removed. Using a small nozzle, spray *Corrosion X*TM (or equivalent) into all available holes. Allow the frame to sit for several minutes to allow excess to drain as it may, then wipe off all external surfaces with a clean, dry cloth. Reassemble seat.
- If the painted surface of the steel tube structure is marred in service or during handling, the affected area should be repainted to prevent corrosion. See instructions in section 1.5.5.3.

1.5.4 Disassembly / Assembly:

1.5.4.1 Disassembly:

- To remove the padded upholstery backrest cover, the shoulder harness must be removed. Pull the flap free from the Velcro® strips on the lower part of the back rest, then slide the cover up and off the back.
- To remove the seat cushion and upholstery: disconnect the 3 flaps from the Velcro® strips on the sides and front of the seat pan. Pull the cushion and upholstery forward off the pan.

- To remove the Herculite seat back cover, loosen and release the strap buckles on the aft side of the seat, then slide the cover off of the seat back frame.
- To remove the Herculite seat pan, remove the screws from the underside of the seat frame.
- Disassembly of the seat frame is straightforward, as all connections utilize standard aircraft hardware.
- To remove the lap belt, loosen and remove bolt, washers, flanged bushing, and nut as shown in Figure 3.4, Detail 1. Likewise, to remove the shoulder harness, loosen and remove bolt, washers, and nut as shown in Figure 3.4.

1.5.4.2 Assembly:

- Refer to the Illustrated Parts List when reassembling the seat frame.
- Replace self-locking type nuts with new hardware when reassembling seat.
- Any time the Herculite seat pan is removed, use new screws for reinstallation.
- To attach the lap belt and shoulder harness, reference Figure 3.4 and use the hardware shown as specified on the illustrated parts list.
- Use standard torques except as follows:
 - The nuts, which retain the lap belts, should be snug but not over-tight to allow rotation of the lap belt fittings.
 - The nuts on the clevis bolts at the upper ends of the two arm assemblies, and the nuts that retain the two eyebolts to which the arms attach, should be snug but not over-tight to allow rotation of the arms for folding.
 - The nuts and bolts which attach the feet (seat track fittings) to the eyebolts at four locations should not be tightened so much as to cause distortion of the cast lugs on the fitting.

1.5.4.3 Adjustments:

- Arm Assemblies: These members are not adjustable.

1.5.5 Seat Repair:

1.5.5.1 Hardware Replacement:

Hardware used throughout the seat is aircraft standard. Hardware should be replaced if corroded, damaged, or excessively worn. Replace self-locking type nuts with new hardware when reassembling seat. Do not substitute hardware - refer to the Illustrated Parts List for correct part numbers. If you encounter difficulty procuring replacement hardware or fittings, contact Aero Twin, Inc. at (907) 274-6166. Refer to previous section for assembly information.

1.5.5.2 Quick Release Fittings

Quick release fittings should be replaced or repaired *immediately* if components are missing, or parts are corroded, damaged or excessively worn. Missing components of a quick release fitting constitutes an un-airworthy seat. Replacement fitting parts can be procured through Aero Twin Inc. at the number listed in section 1.5.5.1.

1.5.5.3 Steel Tube Frame:

Before any repairs may be made to the steel tube frame, written approval must be obtained from the manufacturer, Aero Twin Inc. Contact Aero Twin Engineering Department at (907) 274-6166 or write: Aero Twin Inc., Engineering Dept., 2403 Merrill Field Dr., Anchorage AK, 99501.

NOTE: Arm Assemblies (P/N DFS1-02W), are not eligible for repair. If these parts are found to be bent or cracked, they must be discarded and replaced.

1.5.5.4 Painted Surfaces:

Painted steel surfaces should be maintained and refinished as required to prevent corrosion. When refinishing is required, lightly sand the affected area using fine sandpaper or an abrasive pad (such as 3M *Scotch-Brite*TM). Polish out minor surface nicks or scratches where present. Clean the area thoroughly with a clean cloth wetted with non-petroleum-based solvent to remove any residual oils and dust. Apply a zinc-chromate or equivalent primer coat, then a matching color coat of quality enamel or epoxy-type paint. Follow manufacturer's instructions in preparing and applying primer and color coats.

1.5.5.5 Fabric:

- **Herculite Components:** These components are subject to mandatory replacement at ten-year intervals, but should be replaced when found to be excessively worn, frayed, or torn. Open seams can be re-stitched using nylon thread.
- **Upholstery:** Re-stitch open seams using nylon thread. Small tears can be drawn closed and sewn. Extensive damage usually justifies replacement of the upholstery cover. Seat upholstery fabrics are limited, as shown on drawing DFS1-26-T, to Douglass Interior's Skagit Bay material, part numbers Skagit Bay – 200 (Gazelle), Skagit Bay – 201 (Osage), and Skagit Bay – 03250 (Canyon Gray). If another fabric is desired for the upholstery, contact Aero Twin, Inc. Douglass Interior's and Aero Twin, Inc.'s contact information is:

Douglass Interior Products
2000-124th Ave. N.E.
Bellevue, WA 98005
(425)455-2120
(800)722-7272

Aero Twin, Inc.
2403 Merrill Field Dr.
Anchorage, AK 99501
(907)274-6166

- **Foam:** The seat is not approved for operation without the foam supplied with the seat. If the seat cushions require replacement, only Confor Foam CF-45 (bottom layer), CF-40 (middle layer), and DAX-55 scrim (top layer) are acceptable replacements.

1.5.5.6 Restraint Belts:

Worn, frayed, cut, or otherwise damaged belt assemblies should be replaced or remanufactured by a qualified repair station. Any belt assembly that is found to be missing its manufacturer's data patch must be considered unairworthy and must be replaced.

2.0 Airworthiness Limitations

Aero Twin, Inc. Single Place Folding Seat P/N DFS2T

The Airworthiness Limitations section is FAA/DAS approved and specifies maintenance required under paragraphs 43.16 and 91.403(c) of the Federal Aviation Regulations unless an alternative program has been FAA approved.

This section describes required inspection, maintenance, and replacement items. When repairs are deemed necessary, follow accepted standard practices and/or specific maintenance instructions in Section 1.5 of this manual. This section constitutes Component Airworthiness Limitations which apply to the seat only.

2.1 Scheduled Inspections and Maintenance:

Note: First inspection should be accomplished at next aircraft inspection so that subsequent inspections coincide.

2.1.1 1000 hour or Annual Inspection, whichever occurs first:

- Remove padded upholstery cover.
- Inspect steel tube frame:
 - Tubes for bends, dents, corrosion, or other defects.
 - Welded areas for cracks or other defects.
 - Finish for scratches, abrasion, etc.
- Inspect hardware and fittings:
 - Hardware for security and condition.
 - Quick-release fittings for proper operation and condition.
 - Feet (track fittings) for proper operation, security, and condition.
- Inspect Herculite fabric (seat pan and seat back cover):
 - Fabric for wear, fraying, tearing, or other defects
 - Attachment screws (seat pan) for security
 - Straps and buckles (seat back) for condition and tautness
- Inspect restraint system (lap belts and shoulder harness assemblies):
 - Webbing for cuts, fraying, or other defects.
 - End fittings for security and condition.
 - Buckles for proper operation.
 - Data patches (must be present and legible).
- Inspect overall seat assembly and upholstery for cleanliness and general airworthiness.
- Lubricate all rotating and sliding parts fittings (Corrosion X™ or equivalent).
- Reinstall padded upholstery cover.

FAA Approved: _____

Date: _____

August Orszag
3/27/09

2.1.2 Five-Year Inspection:

- Remove padded upholstery cover.
- Remove Herculite seat pan and seat back cover.
- Inspect steel tube frame:
 - All welded joints using a 10X glass for cracks.
 - (Strip paint from area around any apparent crack and re-inspect).
- Treat all tubing internally with corrosion preventative (*Corrosion X*TM or equivalent).
- Complete all items for a **1000 Hour / Annual Inspection**.
- Reinstall seat pan using new screws; reinstall seat back cover and upholstery cover.

2.1.3 Ten-Year Inspection:

- Remove padded upholstery cover.
- Remove Herculite seat pan and seat back cover and discard.
- Disassemble seat frame.
- Strip paint from all welded joints and inspect using a 10X glass.
- Complete all items for a **5-Year Inspection**.
- Repaint seat frame components.
- Reassemble seat frame using new hardware.
- Install NEW Herculite seat pan and seat back cover
- Reinstall padded upholstery cover.

2.2 Mandatory Replacement

Herculite seat pan and seat back cover, P/N DFS1-06 and DFS1-07W respectively, must be replaced by new parts during 10 year inspection as discussed in 2.1.3.

FAA Approved: August Olson
 Date: 3/27/09

-----End of Section 2.0 Airworthiness Limitations-----

3.0 Illustrated Parts List

Aero Twin, Inc. Single Place Folding Seat P/N DFS2T for Kit No. DFS-KOD

3.1 Complete Parts List:

Item	Qty (per seat)	Part Number	Description	Appears on Fig:
1	1	DFS1-05W-1	Seat Pan Frame	3.2, 3.3, 3.6
2	1	DFS1-04	Back Rest Frame	3.2
3	2	DFS1-02W	Lower Arm	3.2, 3.3, 3.5
4	2	DFS1-03	Upper Arm	3.2
5	1	DFS1-06	Back Rest Cover	3.2
6	1	DFS1-35	Seat Cushion Foam	3.2, 3.7
7	4	ATFS-133	Buckle	3.2
8	A/R	NAS1149F 0532P/0563P	Washer	3.2, 3.3, 3.4
9	4	AN25-14A	Clevis Bolt	3.2, 3.3
10	4	AN5-12A	Bolt	3.3
11	4	40566-15	Retainer	3.3
12	2	MS20392-3C35	Clevis Pin	3.3
13	2	MS24665-212	Cotter Pin	3.3
14		--	Upholstery Covers, Pan & Back	3.2
15	1	5-01-510701REVA (LH) 5-01-515701REVA (RH)	Lap Belt and Shoulder Harness Assembly	3.4
16	4	ATFS-62L	Eye Bolt	3.3
17	A/R	NAS1149F 0432P/0463P	Washer	3.3, 3.4
18	1	NAS77-4-10 or S1003-9A	Bushing	3.4
19	1	AN24-24A	Bolt	3.4
20	2	AN5-7A	Bolt	3.4
21	2	ATFS-115A	Flanged Bushing	3.4
22	1	MS21083N4	Nut	3.4
23	2	AN5-8A	Bolt	3.4
24	4	MS21083N5	Nut	3.2, 3.3, 3.4
25	4	NAS561P8-16	Roll Pin	3.5
26	2	MS22034-1 /1B	Retainer Fitting	3.5
27	21	MS51863-23/23C, S1021A6-8	Screw	3.2, 3.6
28	1	DFS1-07W	Seat Pan	3.6
29	1	DFS2-46TSO	TSO Data Plate	3.3
30	2	DFS2-46TSO-AUX	Cushion TSO Data Plate	3.7
31	1	DFS1-06-2	Seat Back Cushion	3.7
32	1	DFS1-35	Seat Bottom Cushion	3.7
33	1	DFS-KOD-PLCD	Fasten Seat Belt Placard	3.7
Accessories:				
N/A	Optional	ATFS1-09	Storage Bag	(not shown)
N/A	Optional	AT-SRT-01	Removal Tool	(not shown)

Figure 3.1

3.2 FOLDING SEAT OVERVIEW & BACK REST COVER INSTALLATION

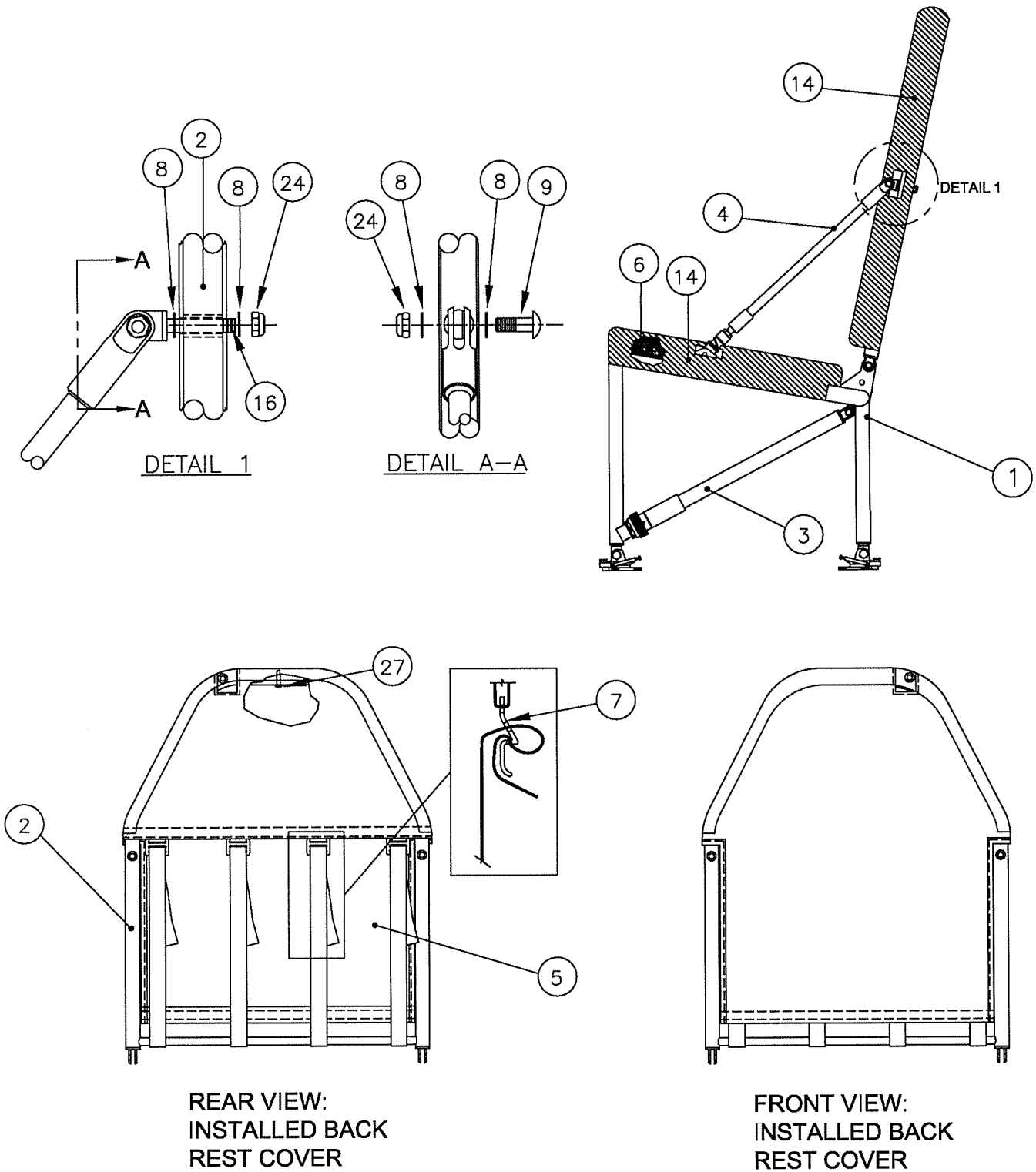

FIGURE 3.2

3.3 SEAT BOTTOM HARDWARE & LOWER ARM INSTALLATION

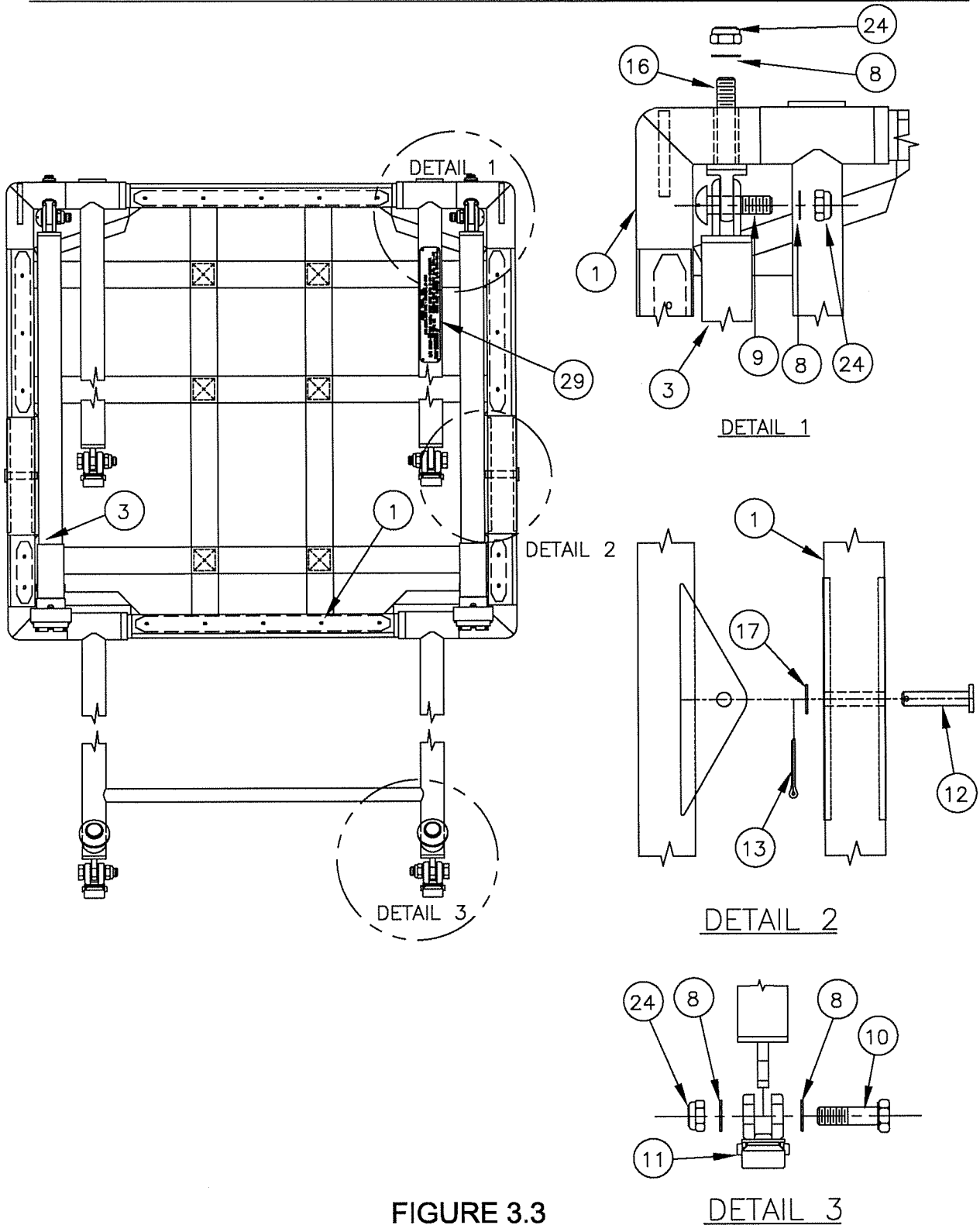

FIGURE 3.3

3.4 SEAT BELT AND BACK INSTALLATION

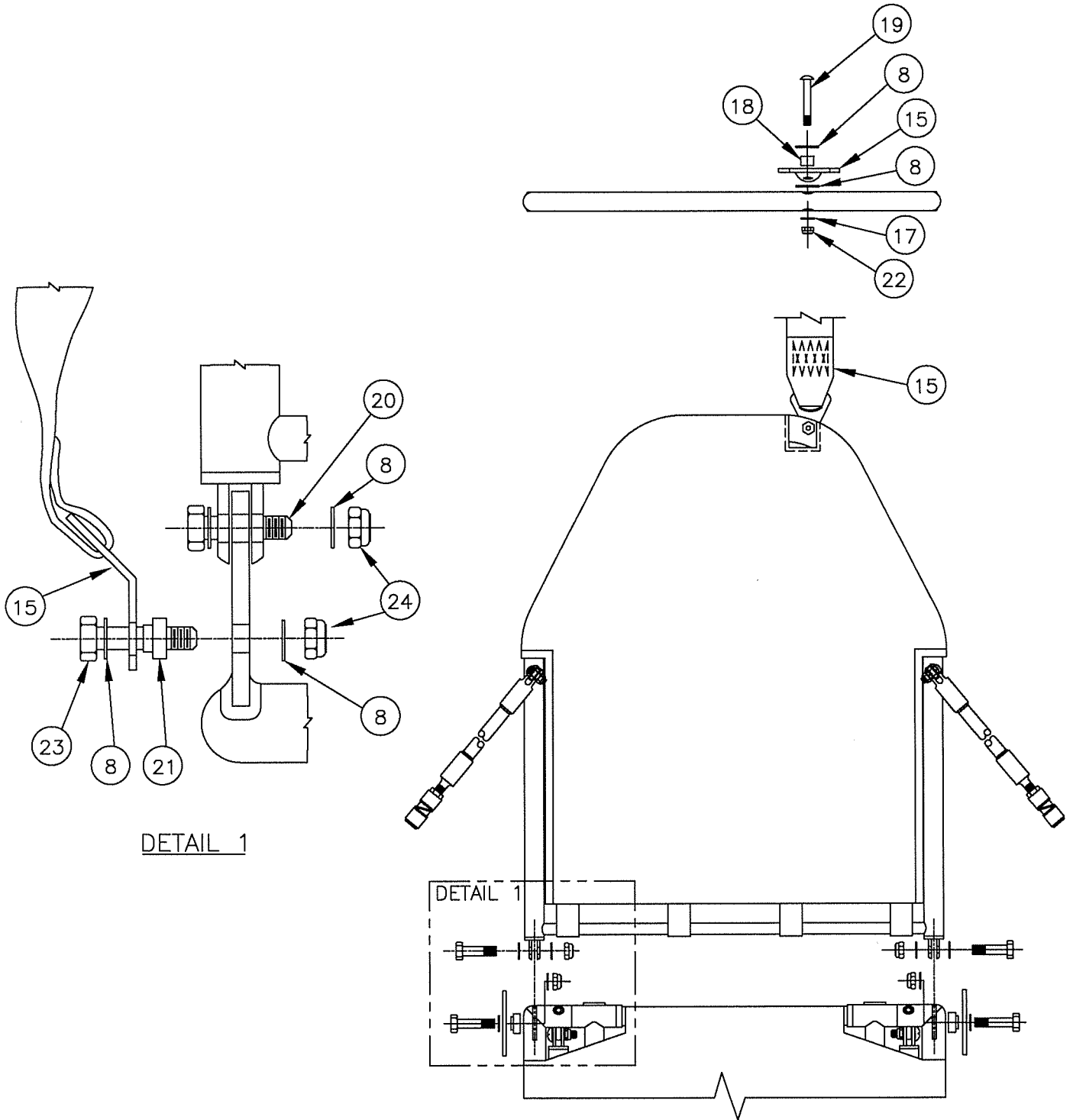

FIGURE 3.4

3.5 LOWER ARM DETAIL

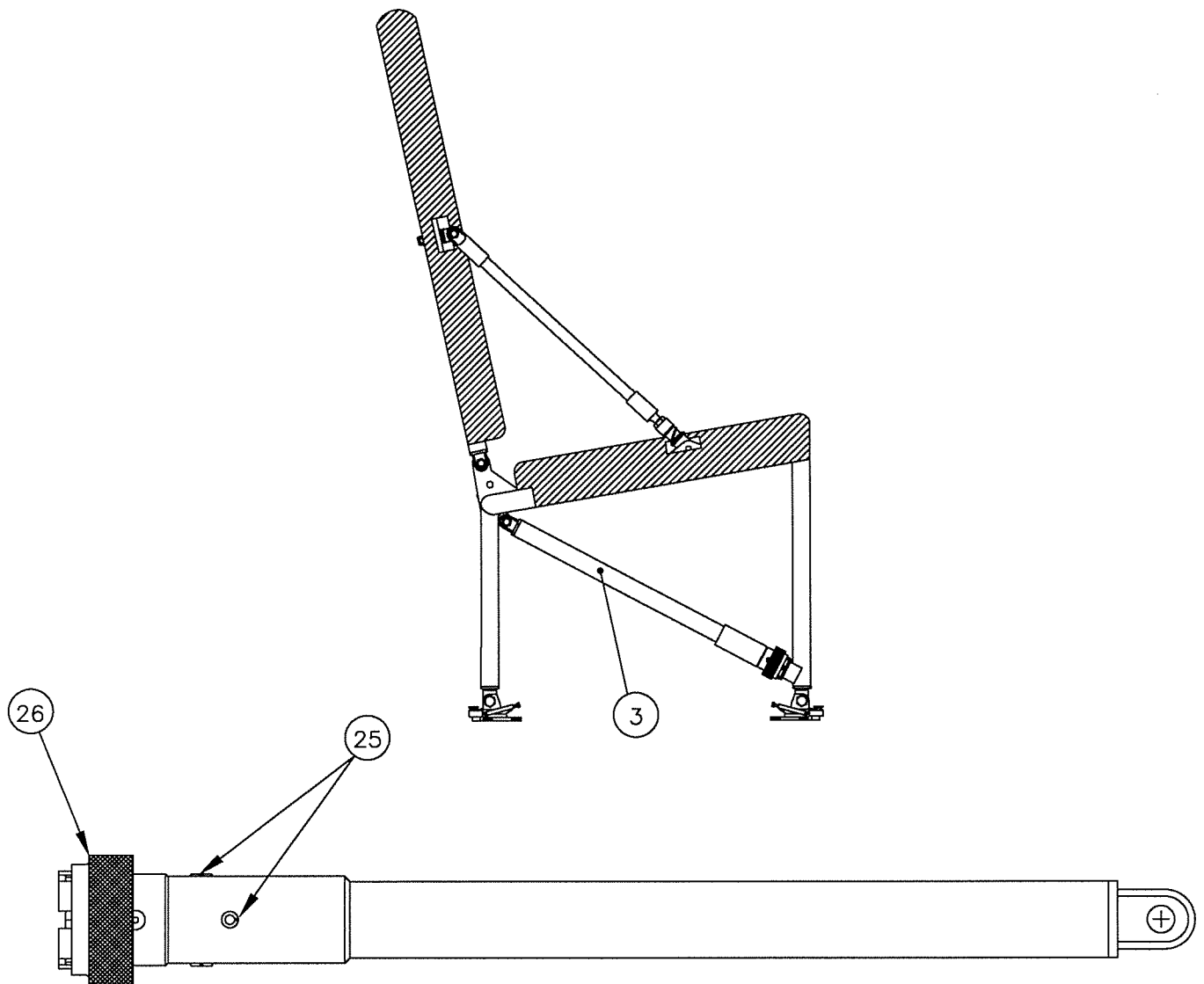

FIGURE 3.5

3.6 SEAT PAN INSTALLATION

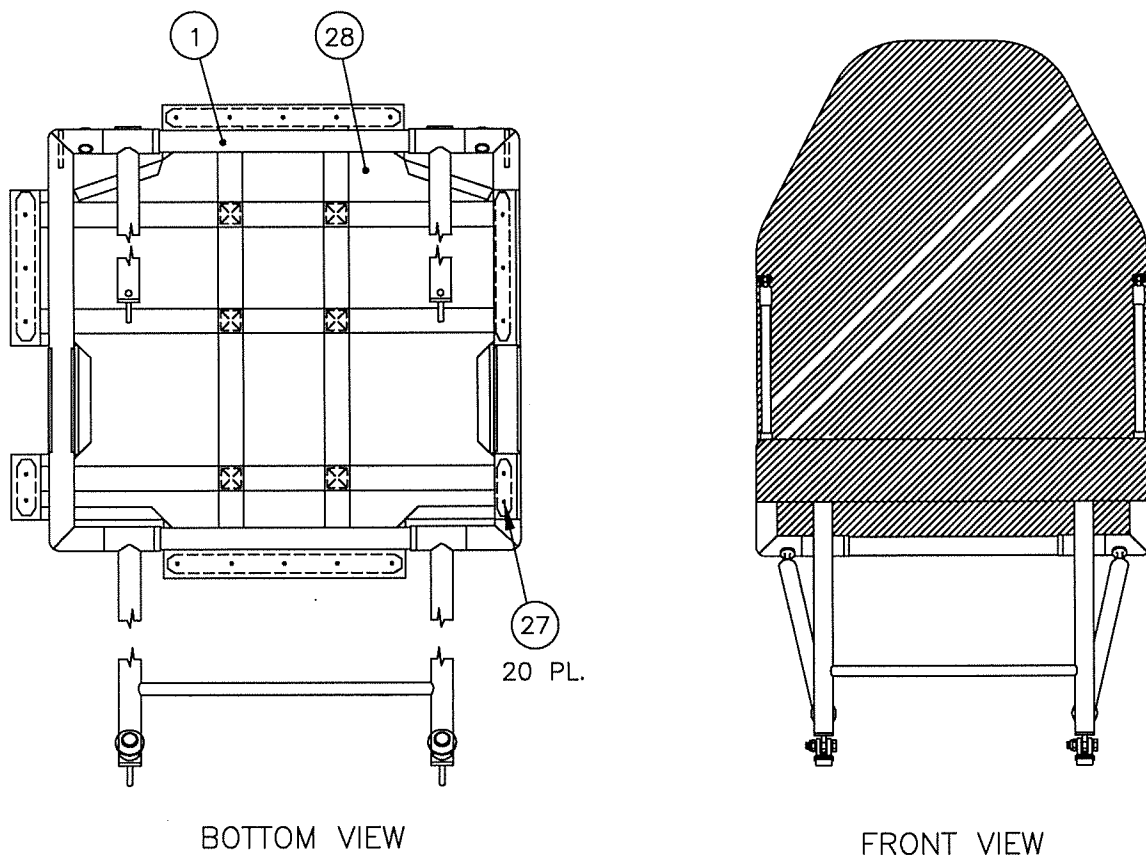
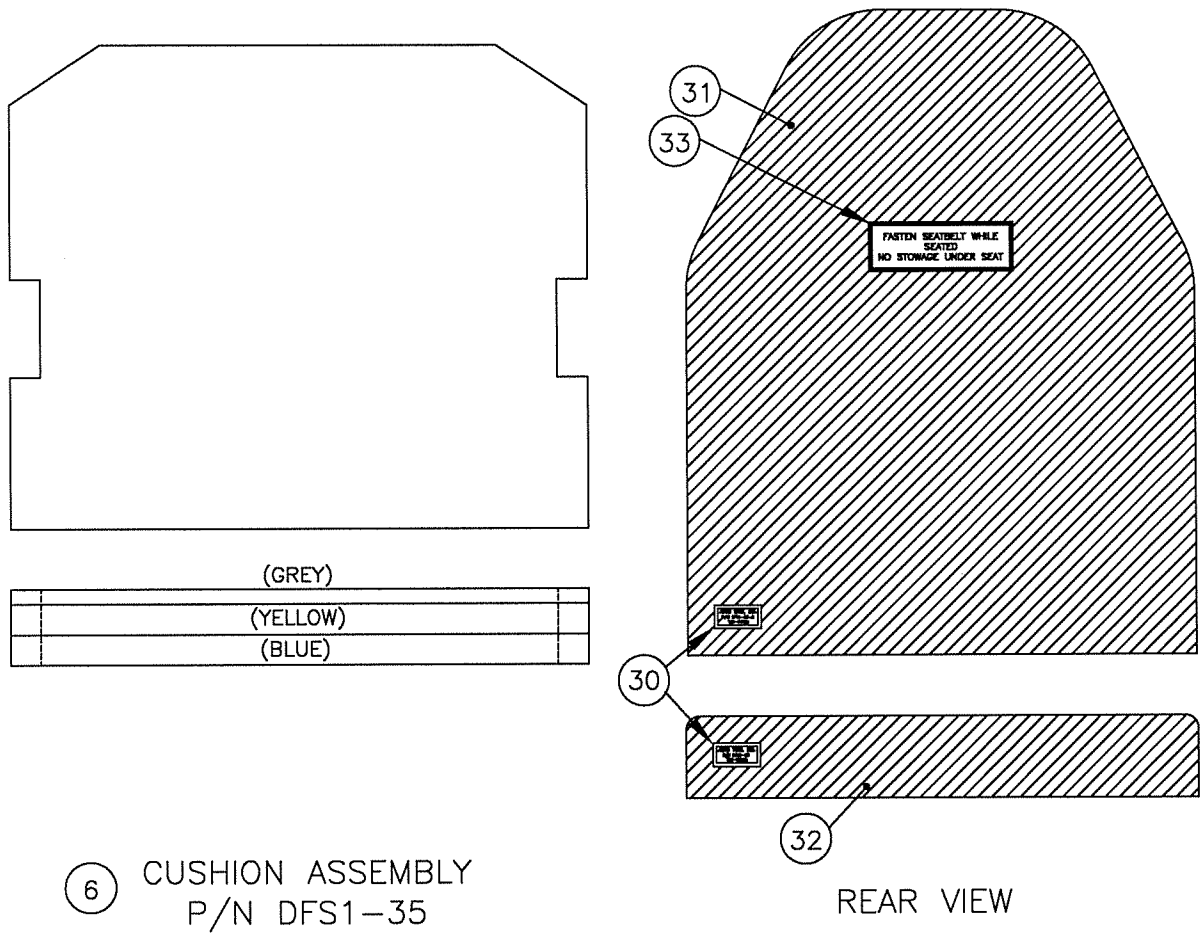

FIGURE 3.6

3.7 CUSHION ASSEMBLY AND DATA PLATE INSTALLATION



⑥ CUSHION ASSEMBLY
P/N DFS1-35

FIGURE 3.7